

① DRAWING LOT II

|    |   |
|----|---|
| NO | GENERAL NOTES   |
|    | <p>All dimensions on the drawing are in MM</p> <p>Draw note from the following the figure dimensions ONLY</p> <p>All Energy tests to be carried out in accordance with electrical and mechanical Eng. Notes</p> <p>Provisions of safety to be notified and approved prior to installation of lines</p> <p>The positions of various electrical items shown on the drawings are to be confirmed to the architect working drawings</p> <p>The contractor shall check all clearances and ensure that all work is carried out in accordance with the applicable standards on site.</p> |
| NO | REVISION NOTES  |
|    |   |

|                |   |
|----------------|---|
| Project:       | NEW LV SWITCHBOARD-NAKURU                     |
| Client:        |   |
| Working Title: | LV SWITCHBOARD - PROPOSED ON-LINE ENGINEERING |
| Sheet No.:     | 01  |
| Revision No.:  |   |
| Design:        | EL/S  |
| Drawn:         | EL/S  |
| Date:          | SUPPLEMENT                                    |
| Checked:       | EL/S  |
| Author:        |   |

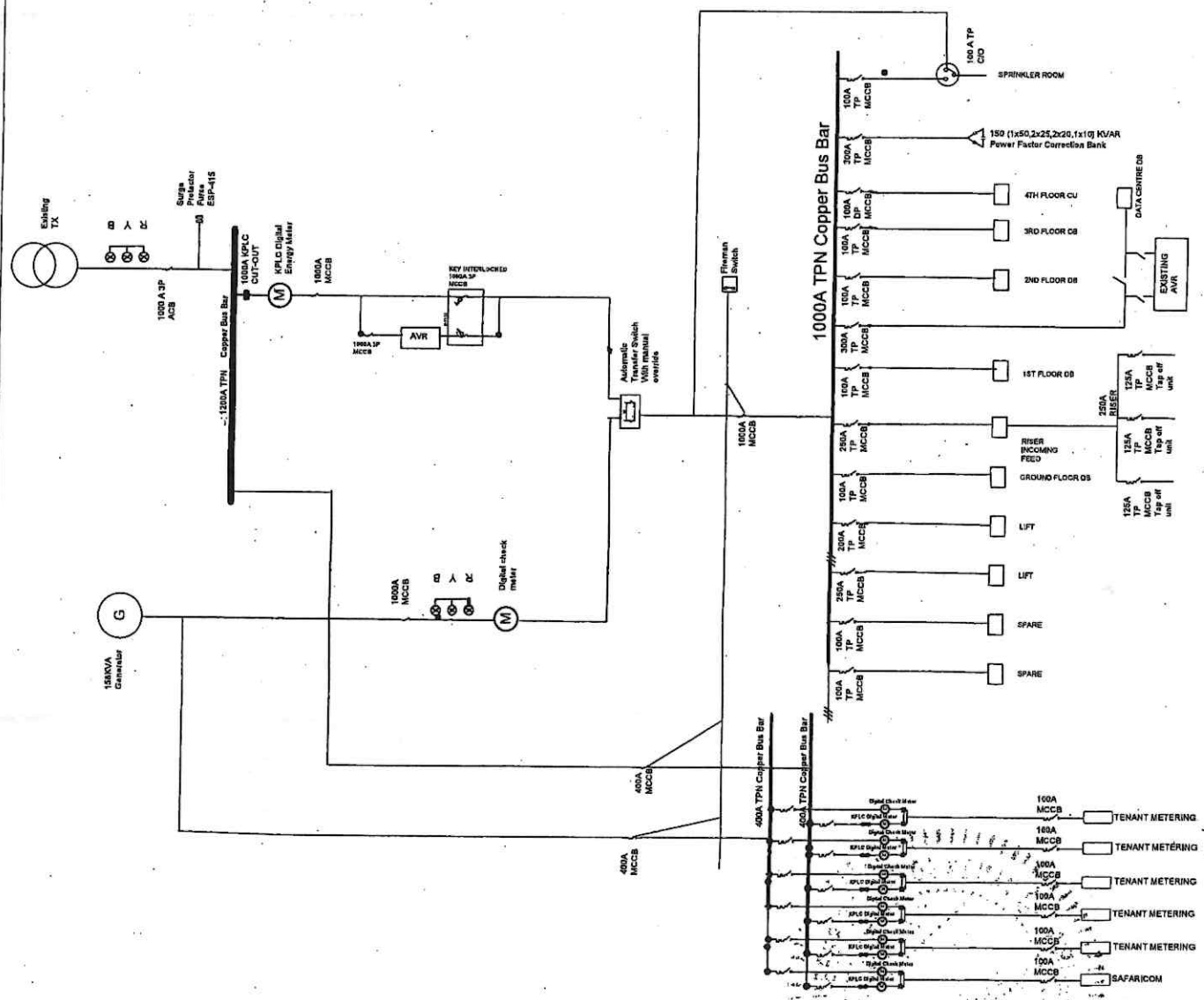
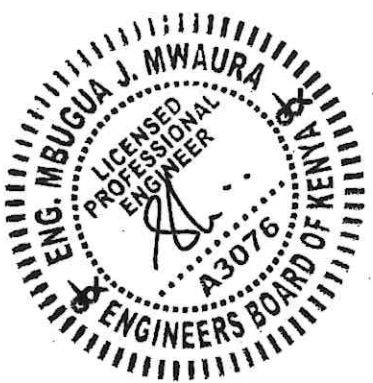

LOT III

|    |  |    |                |
|----|--|----|----------------|
| NO | GENERAL NOTES  | NO | REVISION NOTES |
|    | <p>All dimensions are in the drawing per to IBS.</p> <p>Do not scale from the drawing.</p> <p>Use appropriate dimensions ONLY.</p> <p>All drawings must be read in conjunction with the specification.</p> <p>Exp. layout</p> <p>positions of outlets to be installed and approved prior to installation of base.</p> <p>The positions of various electrical items as shown on the drawings are approximate. Final positions to be determined by the electrical engineering department.</p> <p>The contractor shall check all other drawings and ensure the revisions are coordinated for each side.</p> |    |                |

|               |  |
|---------------|--|
| Project       | NEW LV SWITCHBOARD - ASSURAY               |
| Client        |  |
| Drawing Title | LV SWITCHBOARD - PROPOSED ONE-LINE DIAGRAM |
| Scale         | 1:1  |
| Drawing No.   | 01   |
| Revision No.  |  |
| Checked       | SUS  |
| Drawn         | SUS  |
| Date          | 20/11/2018                                 |
| Checked       | DALE                                       |
| Author        |  |

