



TITLE:
**SPECIFICATION FOR
HEARING PROTECTORS**

Part 1: Earmuffs

Doc. No.	KP1/6C.1/13/TSP/01/013-1
Issue No.	1
Revision No.	0
Date of Issue	2015-10-09
Page 1 of 15	

TABLE OF CONTENTS

0.1 Circulation List

0.2 Amendment Record

FOREWORD

1. SCOPE
2. REFERENCES
3. TERMS AND DEFINITIONS
4. REQUIREMENTS
5. TESTS AND INSPECTION
6. MARKING AND PACKING
7. DOCUMENTATION

ANNEX A: *Guaranteed Technical Particulars (to be filled and signed by the Manufacturer and submitted together with relevant copies of the Manufacturer's catalogues, brochures, drawings, technical data, sales records, four customer reference letters, the manufacturer's experience and copies of complete test reports for tender evaluation, all in English Language)*

Issued by: Head of Section, Standards Development

Authorized by: Head of Department, standards

Signed:

Signed:

Date: 2015-10-09

Date: 2015-10-09



TITLE:
**SPECIFICATION FOR
HEARING PROTECTORS**
Part 1: Earmuffs

Doc. No.	KP1/6C.1/13/TSP/01/013-1
Issue No.	1
Revision No.	0
Date of Issue	2015-10-09
Page 2 of 15	

0.1 Circulation List

COPY NO.	COPY HOLDER
1	Manager, Standards
Electronic copy (pdf) on Kenya Power server (http://172.16.1.40/dms/browse.php?fFolderId=23)	

0.2 Amendment Record

Rev No.	Date (YYYY-MM-DD)	Description of Change	Prepared by (Name & Signature)	Approved by (Name & Signature)
0	2015-10-09	New Issue	Michael Apudo	Dr. Eng. Peter Kimemia

Issued by: Head of Section, Standards Development

Authorized by: Head of Department, standards

Signed:

Signed:

Date: 2015-10-09

Date: 2015-10-09



TITLE:
**SPECIFICATION FOR
HEARING PROTECTORS**
Part 1: Earmuffs

Doc. No.	KP1/6C.1/13/TSP/01/013-1
Issue No.	1
Revision No.	0
Date of Issue	2015-10-09
Page 3 of 15	

FOREWORD

This specification has been prepared by the Standards Department in collaboration with Human Resource Services Department; Safety, Health & Environment Department (SHE) of The Kenya Power and Lighting Company Limited (KPLC/Kenya Power) and The Kenya Electrical Trade & Allied Workers Union (KETAWU). The specification lays down requirements for – Hearing protectors - Earmuffs. It is intended for use by Kenya Power in purchasing these items.

The supplier shall submit information which confirms satisfactory service experience with products which fall within the scope of this specification

1. SCOPE

- 1.1. This document specifies the design and performance, methods of test, marking and user information for Earmuffs for general use by KPLC.
- 1.2. The specification also covers inspection and test of the earmuffs as well as schedule of Guaranteed Technical Particulars (GTP) to be filled, signed by the manufacturer and submitted for tender evaluation.
- 1.3. The specification stipulates the minimum requirements for the Hearing protectors - Earmuffs in the company and it shall be the responsibility of the supplier to ensure adequacy of the design, good engineering practice, adherence to the specification and applicable standards and regulations as well as ensuring good workmanship in the manufacture of the items for The Kenya Power & Lighting Company.
- 1.4. The specification does not purport to include all the necessary provisions of a contract.

2. REFERENCES

The following standards contain provisions which, through reference in this text constitute provisions of this specification. Unless otherwise stated, the latest editions (including amendments) apply.

ISO 4869: Acoustics – Hearing protectors -- Part 1: Subjective method for the measurement of sound attenuation – Part 2: Estimation of effective A-weighted sound pressure levels when hearing protectors are worn

KS 2093-1: Hearing protectors — Part 1: Ear-muffs — Specification

Issued by: Head of Section, Standards Development

Authorized by: Head of Department, standards

Signed:

Signed:

Date: 2015-10-09

Date: 2015-10-09



TITLE:
SPECIFICATION FOR HEARING PROTECTORS
Part 1: Earmuffs

Doc. No.	KP1/6C.1/13/TSP/01/013-1
Issue No.	1
Revision No.	0
Date of Issue	2015-10-09
Page 4 of 15	

3. TERMS AND DEFINITIONS

For the purpose of this specification, the definitions given in the reference standards shall apply

4. REQUIREMENTS

4.1. Service Conditions

The earmuffs shall be suitable for use outdoors in tropical climate with:

- a) Altitudes of up to 2200m above sea level,
- b) Humidity of up to 95%,
- c) Average ambient temperature of +30°C with a minimum of -1°C and a maximum of +40°C
- d) Heavy saline conditions along the coast and
- e) Isokeraunic levels of up to 180 thunderstorm days per year.

4.2. MATERIALS AND CONSTRUCTION

4.2.1. Materials

4.2.1.1. Those parts of the earmuff that may come into contact with the skin:

- a) Shall be non-staining, soft, pliable and not known to be likely to cause skin irritation, allergic reaction or any other adverse effect on health.
- b) Shall be resistant to skin oil, hair oil and ear wax.
- c) Shall be moisture proof, heat resistant and cold proof.

4.2.1.2. The materials used shall not be damaged readily under normal handling and its strength, hardness and elasticity shall be suitable for the purpose it is to serve.

4.2.1.3. Earmuffs shall be made of materials that are capable of being cleaned or sterilized. All materials shall be visibly unimpaired after cleaning by the method specified by the manufacturer.

4.2.2. Construction

4.2.2.1. Hearing protectors – earmuffs shall be designed, manufactured and tested in accordance with KS 2093-1 and ISO 4869.

Issued by: Head of Section, Standards Development	Authorized by: Head of Department, standards
Signed: 	Signed: 
Date: 2015-10-09	Date: 2015-10-09



TITLE:
**SPECIFICATION FOR
HEARING PROTECTORS**
Part 1: Earmuffs

Doc. No.	KP1/6C.1/13/TSP/01/013-1
Issue No.	1
Revision No.	0
Date of Issue	2015-10-09
Page 5 of 15	

- 4.2.2.2. All parts of the earmuffs shall be radiused, finished smooth and be free from sharp edges.
- 4.2.2.3. Earmuffs whose cushions and/ or liners are intended by the manufacturers to be replaced by the wearer shall not require the use of tools for this purpose.
- 4.2.2.4. All universal earmuffs shall be provided with a head strap.

4.3. PERFORMANCE REQUIREMENTS

4.3.1. General

The requirements specified in clauses 4.3.2 to 4.3.12 shall be satisfied. Specimens of earmuffs shall be conditioned and tested as specified in clauses 7.1.1 and 7.1.2 of KS 2093-1. The scheme of testing shall be as specified in clause 7.1.3 of KS 2093-1.

4.3.2. Adjustability

When tested in accordance with clause 7.2 of KS 2093-1, the adjustability shall be as below:

a) Normal size range' earmuffs - Over-the-head and under-the-chin earmuffs.

For each of the combinations of test dimensions shown by the letter N in Table 1, the range of adjustment of the cups/headband and of the width between the cushions shall enable the ear-muffs to be fitted to the fixture.

b) Small size range' earmuffs - Over-the-head earmuffs

For each of the combinations of test dimensions shown by the letter S in Table 1, the range of adjustment of the cup/headband and of the width between the cushions shall enable the ear -muffs to be fitted to the fixture.

c) 'Large size range' ear muffs - Over-the-head earmuffs.

For each of the combinations of test dimensions shown by the letter L in Table 1, the range of adjustment of the cup/headband and of the width between the cushions shall enable the earmuffs to be fitted to the fixture.

Issued by: Head of Section, Standards Development

Authorized by: Head of Department, standards

Signed:

Signed:

Date: 2015-10-09

Date: 2015-10-09

Table 1 - Test dimensions (over-the-head and under-the-chin earmuffs)
 Dimensions are in millimetres

Head depth	Width		
	125	145	155
75	S	N	-
90	N	N	N
105	-	N	L

N indicates ear - muffs 'normal' size range
 S indicates ear - muffs 'small' size range
 L indicates ear - muffs 'large' size range
 - Indicates no requirements

Note. The dimensions given in table 1 have chosen to cover appropriate combinations of the head width and head height of the 5th, 50th and 95th "percentiles" of the adult population.

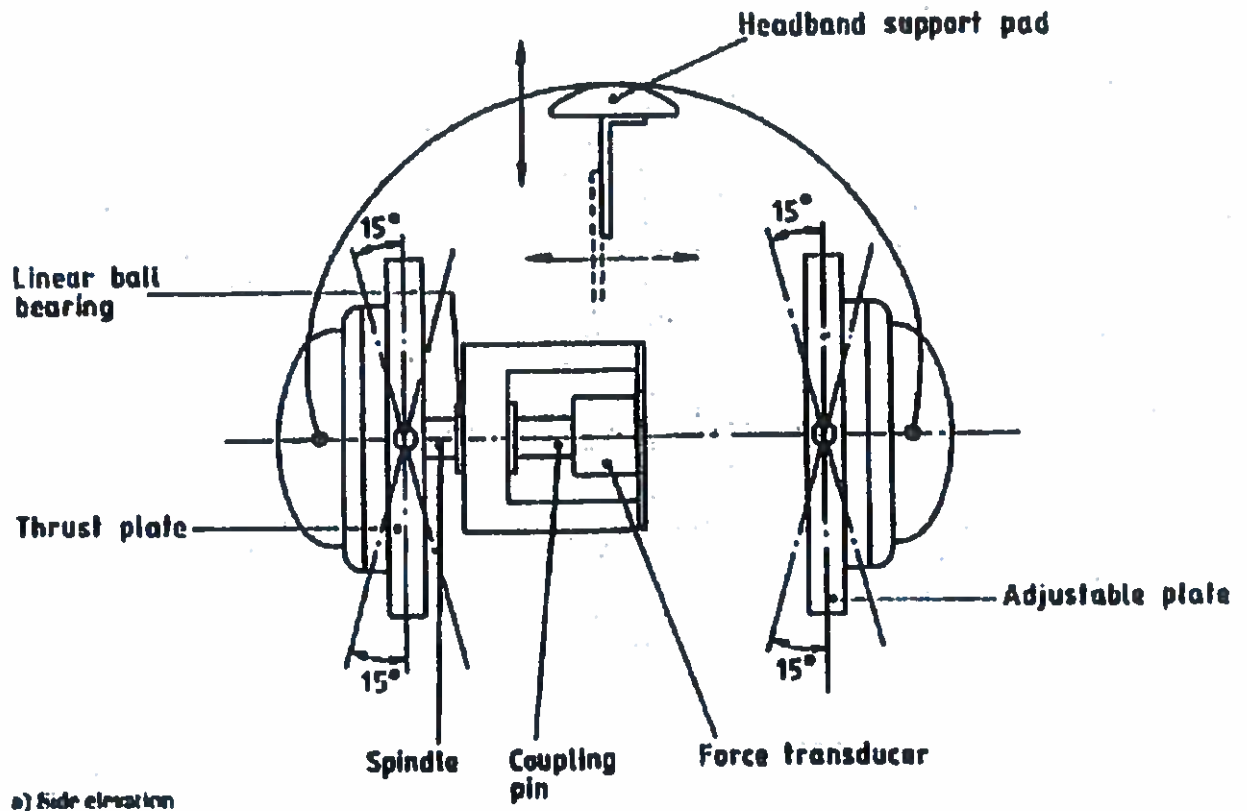

Issued by: Head of Section, Standards Development

Authorized by: Head of Department, standards

Signed:



Signed:



Date: 2015-10-09

Date: 2015-10-09

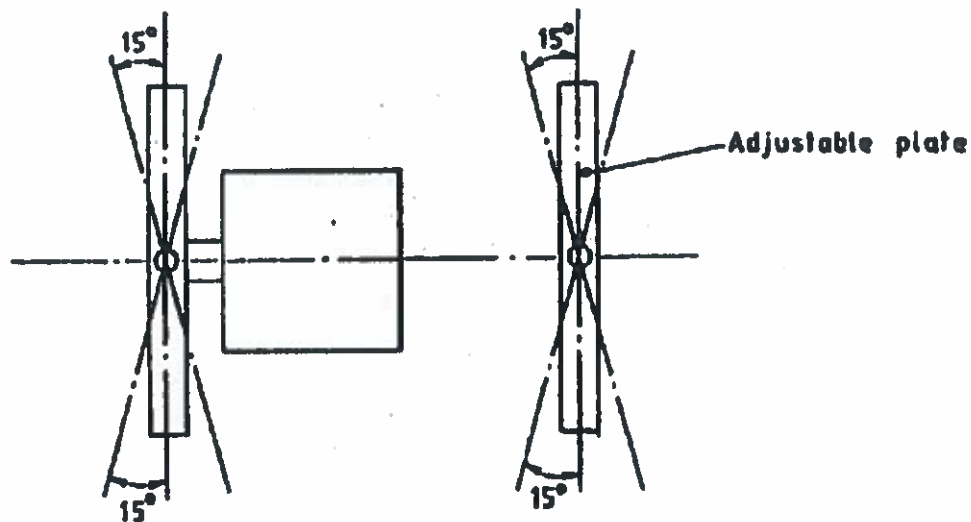

b) plain view

Note: The pinna stimulators shown in figure 2 of KS 2093-1:2006 are fitted to the plates of the fixtures so, that the holes at the centres of the simulators lie on the horizontal axis through the force transducer.

Fig. 1 - Mounting fixture for measurement of rotation of cups and for tests for headband force and cushion pressure and for adjustability.

4.3.3. Cup/Headband rotation

When tested in accordance with clause 7.3 of KS 2093-1., the contact between the cushions and the plates of the fixture shall be continuous insofar as it provides an unbroken barrier between the inside and outside perimeters of the cushions.

4.3.4. Lead and force

When tested in accordance with clause 7.4 of KS 2093-1, the headband force shall be not greater than 14 N.

4.3.5. Cushion pressure

When tested in accordance with clause 7.5 of KS 2093-1, the cushion pressure shall be not greater than 4500 Pa.

Issued by: Head of Section, Standards Development

Authorized by: Head of Department, standards

Signed:



Signed:



Date: 2015-10-09

Date: 2015-10-09



TITLE:
**SPECIFICATION FOR
HEARING PROTECTORS**

Part 1: Earmuffs

Doc. No.	KP1/6C.1/13/TSP/01/013-1
Issue No.	1
Revision No.	0
Date of Issue	2015-10-09
Page 8 of 15	

4.3.6. Resistance to damage when dropped.

Unless clause 4.3.7 is to be satisfied, the ear-muffs (except for replaceable cushions) shall not crack when tested in accordance with clause 7.6 of KS 2093-1. Neither shall any part of the ear-muffs become detached, such that correct reassembly requires the use of either tool or a replacement part.

4.3.7. Resistance to low temperature

When tested in accordance with clause 7.7 of KS 2093-1, the ear-muffs (except for replaceable cushions) shall not crack. Neither shall any part of the earmuffs become detached, such that correct re-assembly requires the use of either a tool or a replacement part.

4.3.8. Change in headband force (including optional resistance to high temperature).

The headband force shall not change by more than $\pm 20\%$ from that measured in accordance with clause 7.4 of KS 2093-1 after the earmuffs have been subjected to the appropriate conditioning and tests specified in clauses 7.1.3.1 to 7.1.3.12 of KS 2093-1.

4.3.9. Insertion loss

The standard deviations reported in accordance with clause 7.11.4 of KS 2093-1, shall be not greater than 4.0 dB in four or more adjacent one-third-octave bands, and not greater than 7.0 dB in any individual one-third-octave band.

4.3.10. Resistance to leakage

In the case of liquid filled cushions, they shall not leak when the earmuffs are tested in accordance with 7.12 of KS 2093-1.

4.3.11. Ignitability

When tested in accordance with clause 7.13 of KS 2093-1, no part of the earmuffs shall ignite or continue to glow after the removal of the heated rod.

4.3.12. Minimum attenuation.

When tested in accordance with clause 7.14 of KS 2093-1 the values (Mf-sf) of the earmuff shall be not less than the data in table 2.

Issued by: Head of Section, Standards Development

Signed:

Date: 2015-10-09

Authorized by: Head of Department, standards

Signed:

Date: 2015-10-09

Table 2 - Attenuation requirements for earmuffs.

F in Hz	(Mf -sf) in dB
125	5
250	8
500	10
1,000	12
2,000	12
4,000	12
8,000	12

Mf are the mean attenuation data and sf the standard deviations according to Appendix 1 of KS 2093-1

4.4. WORKMANSHIP AND FINISH

The finished and assembled earmuff shall have no any burrs on edges. All sharp corners shall be removed. The metallic head-strap for fastening over the head shall be smooth, free from seams, pits, die marks and rustproof.

4.5. QUALITY MANAGEMENT SYSTEM

- 4.5.1. The supplier shall submit a quality assurance plan (QAP) that will be used to ensure that the requirements for protection, ergonomic characteristics, innocuousness, mechanical properties, marking of the earmuff, will fulfill the requirements stated in the contract documents, standards, specifications and regulations.
- 4.5.2. The Manufacturer's Declaration of Conformity to applicable standards and copies of quality management certifications shall be submitted with the tender for evaluation.

5. TESTS AND INSPECTION

- 5.1. The earmuff shall be inspected and tested in accordance with ISO 4869, KS 2093-1 and the requirements of this specification. It shall be the responsibility of the supplier to perform or to have performed all the tests specified.
- 5.2. Copies of previous **Test Reports confirming conformity to clause 4 for the earmuff issued by a third party testing laboratory that is accredited to ISO/IEC 17025** shall be submitted with the tender for the purpose of technical evaluation. The accreditation certificate

Issued by: Head of Section, Standards Development

Authorized by: Head of Department, standards

Signed:



Signed:



Date: 2015-10-09

Date: 2015-10-09



TITLE:
SPECIFICATION FOR HEARING PROTECTORS
Part 1: Earmuffs

Doc. No.	KP1/6C.1/13/TSP/01/013-1
Issue No.	1
Revision No.	0
Date of Issue	2015-10-09
Page 10 of 15	

for the third party testing laboratory shall also be submitted with the tender (all in English Language).

- 5.3. Test Reports for the earmuff to be supplied under the contract shall be submitted to The Kenya Power & Lighting Company for approval before shipment/delivery.
- 5.4. The earmuff shall be subject to acceptance tests at the manufacturer's works before dispatch. Acceptance tests (routine & sample tests) will be witnessed by at least two (2) Tender Processing Committee (TPC) members appointed by The Kenya Power and Lighting Company Limited (KPLC). Routine and sample test reports for the earmuffs to be supplied shall be submitted to KPLC for approval before shipment of the goods.
- 5.5. On receipt of the earmuffs, KPLC will inspect them and may perform or have performed any of the relevant tests in order to verify compliance with the specification. The supplier shall replace without charge to KPLC, earmuffs which upon examination, test or use fail to meet any of the requirements in the specification

6. MARKING AND PACKING

6.1. Marking

The earmuffs shall be durably marked with following information:

- a) The name, trade mark or other identification of the manufacturer
- b) Model designation
- c) In the case of ear muffs intended by the manufacturer to be worn in a particular orientation, an indication of the **FRONT** and /or **TOP** of the cups, and /or an indication of **LEFT** and **RIGHT** cup.

6.2. Packing

- 6.2.1. Earmuffs shall be suitably packed in polyethylene envelopes to avoid scratching against each other before packing them in cartons. Each carton shall contain 100 earmuffs.
- 6.2.2. The polyethylene envelopes provided for packaging shall be able to protect the earmuffs every time after use for the lifetime of the earmuffs.
- 6.2.3. The following information should be given on the earmuffs whenever practical or on the packaging:
 - a) The name, trade mark or other identification of the manufacturer
 - b) Model designation
 - c) International care label symbols;

Issued by: Head of Section, Standards Development

Authorized by: Head of Department, standards

Signed:

Signed:

Date: 2015-10-09

Date: 2015-10-09



TITLE:
SPECIFICATION FOR HEARING PROTECTORS
Part 1: Earmuffs

Doc. No.	KP1/6C.1/13/TSP/01/013-1
Issue No.	1
Revision No.	0
Date of Issue	2015-10-09
Page 11 of 15	

- d) The number of Standard of Manufacture.
- e) The letters, "Property of KPLC".

7. DOCUMENTATION



7.1. The bidder shall submit its tender complete with technical documents required by Annex A (Guaranteed Technical Particulars) for tender evaluation. The technical documents to be submitted (all in English language) for tender evaluation shall include the following:

- a) Guaranteed Technical Particulars fully filled and signed by the manufacturer;
- b) Copies of the Manufacturer's catalogues, brochures, drawings and technical data;
- c) Sales records and customer reference letters;
- d) Details of manufacturing capacity and the manufacturer's experience;
- e) Copies of required type test reports by a third party testing laboratory accredited to ISO/IEC 17025;
- f) Copy of accreditation certificate to ISO/IEC 17025 for the testing laboratory.
- g) Manufacturer's warranty and guarantee
- h) Manufacturer's letter of authorization, copy of the manufacturer's ISO 9001:2008/ KEBS Diamond mark certificate and other technical documents required in the tender.

7.2. The successful bidder (supplier) shall submit the following documents/details to The Kenya Power & Lighting Company for approval before manufacture:

- a) Guaranteed Technical Particulars,
- b) Design Drawings and construction details of the earmuffs,
- c) Quality assurance plan (QAP) that will be used to ensure that the earmuffs design, material, workmanship, tests, service capability, maintenance and documentation will fulfill the requirements stated in the contract documents, standards, specifications and regulations. The QAP shall be based on and include relevant parts to fulfill the requirements of ISO 9001:2008
- d) Detailed test program to be used during factory testing,
- e) Marking details and method to be used in marking the earmuffs,
- f) Manufacturer's undertaking to ensure adequacy of the design, good engineering practice, adherence to the specification and applicable standards and regulations as well as ensuring good workmanship in the manufacture of the earmuffs for The Kenya Power & Lighting Company
- g) Packaging details.

7.3. The supplier shall submit recommendations for use, care, storage and routine inspection/testing procedures, all in the English Language, during delivery of the earmuffs to KPLC stores. The following information shall be submitted with the supplied earmuffs:

Issued by: Head of Section, Standards Development	Authorized by: Head of Department, standards
Signed: 	Signed: 
Date: 2015-10-09	Date: 2015-10-09



TITLE:
**SPECIFICATION FOR
HEARING PROTECTORS**

Part 1: Earmuffs

Doc. No.	KP1/6C.1/13/TSP/01/013-1
Issue No.	1
Revision No.	0
Date of Issue	2015-10-09
Page 12 of 15	

7.3.1. Wearer information

The following information for the wearer shall be supplied with earmuffs:

- a) Trade mark, or other means of identification, of manufacturer, importer or distributor
- b) Model designation
- c) As appropriate the statement(s):
 - (i) This model of earmuff has satisfied the optional requirements at 50°C
 - (ii) This model of earmuffs has satisfied the optional requirements at -20°C.

Note: *These statements may be combined.*

- d) Description of the type of headband and of the cushions
- e) Method of fitting/adjustments
- f) For small/large size range' ear-muffs as appropriate a warning on packaging box; "Small /large size range ear-muffs. Refer to wearer information".
- g) For each mode of wearing, the following sounds attenuation values:
 - (i) Mean value and standard deviation at each test frequency
 - (ii) APV value at each test frequency in accordance with ISO/DIS 4869-2 with the parameter a=1
 - (iii) H , M and L Value in accordance with ISO/DIS 4869-2 with the parameter a=1
 - (iv) SNR-value in accordance with ISO/DIS 4869-2 with the parameter a=1;

Note: *Each set of values shall be given equal prominence.*

- h) Recommendation that the wearer should ensure that:
 - (i) The ear-muffs are fitted, adjusted and maintained in accordance with the manufacturer's instructions.
 - (ii) The ear-muffs are worn at all times in noisy surroundings.
 - (iii) The ear -muffs are regularly inspected for serviceability;
 - (iv) Properly stored.
- i) A warning that, if the recommendations given in (i) above are not adhered to the protection afforded by the ear -muffs will be severely impaired
- j) Methods of cleaning and disinfecting which shall specify, and require the use of, cleaning agents that are known not to be harmful to the wearer.
- k) The statement ` This product may be adversely affected by certain chemical substances. Further information should be sought from the manufacturer.'
- l) The statement, "Earmuffs and in particular cushions may deteriorate with use and should be examined at frequent intervals for cracking and leakage", for example.
- m) A warning to avoid accidents and incidents due to impaired hearing.
- n) Recommended storage conditions before and after use.
- o) Recommended product life;
- p) Recommended number of times it

Issued by: Head of Section, Standards Development

Authorized by: Head of Department, standards

Signed:

Signed:

Date: 2015-10-09

Date: 2015-10-09



TITLE:
**SPECIFICATION FOR
HEARING PROTECTORS**
Part 1: Earmuffs

Doc. No.	KP1/6C.1/13/TSP/01/013-1
Issue No.	1
Revision No.	0
Date of Issue	2015-10-09
Page 13 of 15	

- q) The designation/reference and other information required when ordering replacement cushions.

Note: *If appropriate, the method of cushions replacement*

- r) The mass of the earmuffs
s) The address from which additional information can be obtained

7.3.2. Additional information

The following shall be available from the manufacturer on request:

- a) Range of head sizes fitted
b) Information as specified in clause 7.3.1
c) Results of tests performed in accordance with this standard.
d) The name and country of the test laboratory, which performed the test, specified in 7.3.2(c) and the date of the tests.

-----SPACE LEFT BLANK-----

Issued by: Head of Section, Standards Development

Authorized by: Head of Department, standards

Signed:

Signed:

Date: 2015-10-09

Date: 2015-10-09



TITLE:
SPECIFICATION FOR HEARING PROTECTORS
Part 1: Earmuffs

Doc. No.	KP1/6C.1/13/TSP/01/013-1
Issue No.	1
Revision No.	0
Date of Issue	2015-10-09
Page 14 of 15	

ANNEX A: Guaranteed Technical Particulars (to be filled and signed by the Manufacturer and submitted together with relevant copies of the Manufacturer's catalogues, brochures, drawings, technical data, sales records, four customer reference letters, the manufacturer's experience and copies of complete type test reports for tender evaluation, all in English Language)

Tender No.

Clause number	KPLC requirement		Bidder's offer (indicate full details of the offered for the earmuffs)
Manufacturer's Name and address			specify
Brand name or designation			specify
Country of Manufacture			specify
Bidder's Name and address			specify
1.	Scope		specify
1.1-1.3			
2.	Applicable Standards	KS 2093-1 or equivalent	specify
3.	Terms & Definitions		specify
4.	REQUIREMENTS		specify
4.1	Service Conditions	No deleterious changes at -20 ⁰ C to +50 ⁰ C	specify
4.2	Design & Construction		specify
4.2.1	Materials properties	Non staining, soft pliable and non-skin irritation	Show proof by stating materials used conforming to the attributes
		Resistant to skin oil, hair oil or ear wax	
		Moisture proof, heat resistant & cold proof	
		Suitable strength and harness	
		Readily cleaned and sterilized	
4.2.2	Construction	Radiused, smooth and free from sharp edges	Show proof by stating materials used conforming to the attributes
		Replaceable cushions/liners without use of tools	
4.2.3	Performance – as per KS 2093-1		Attach test reports as per KS 2093-1 or equivalent to confirm conformity performance tests
	Adjustability	As per table 1	
	Cup rotation	The contact between the cushions and the plates of the fixture as per KS 2093-1	
	Lead and force	Lead band force < 14 N	
	Cushion pressure	< 4,500 Pa	
	Resistance to damage	No damage when dropped	
	Resistance to temperature	No change	
	Change in headband force	< ± 20 %	

Issued by: Head of Section, Standards Development

Authorized by: Head of Department, standards

Signed:

Signed:

Date: 2015-10-09

Date: 2015-10-09



TITLE:
SPECIFICATION FOR HEARING PROTECTORS
Part 1: Earmuffs

Doc. No.	KP1/6C.1/13/TSP/01/013-1
Issue No.	1
Revision No.	0
Date of Issue	2015-10-09
Page 15 of 15	

Clause number	KPLC requirement	Bidder's offer (indicate full details of the offered for the earmuffs)
	Insertion loss	
	Resistance to leakage	
	Ignitability	
	Minimum attenuation	
	Workmanship and finish	
		Show proof by stating materials used conforming to the attributes
4.5	Quality Management System	Provide
	Quality Assurance Plan	Provide
	Copy of ISO 9001:2008 Certificate	Provide
	Manufacturer's experience	Provide
	Manufacturing Capacity (units per month)	Provide
	List of previous customers	Provide
	Customer reference letters	Provide
5.1	Test standards and responsibility of carrying out tests	Provide
5.2	Copies of Type Test Reports submitted with tender	Provide
5.3	Acceptance tests to be witnessed by KPLC at factory before shipment	Provide
5.4	Test reports to be submitted by supplier to KPLC for approval before shipment	Provide
5.5	Replacement of rejected earmuffs	Provide
6.1	Markings	Provide
6.2	Packing	Provide
7.1	Documents submitted with tender	Provide
7.2	Documents to be submitted by supplier to KPLC for approval before manufacture	Provide
8.0	Statement of compliance to specification	Provide

.....
Manufacturer's Name, Signature, Stamp and Date

NOTE: *The Guaranteed Technical Particulars (GTP) shall form the basis of technical tender evaluation. Bidders shall ensure that the offered values for the item conform to the values in the test reports and their certificates, catalogue references and/or brochures. Failure to adhere by this requirement shall lead to automatic disqualification at the technical evaluation stage.*

Issued by: Head of Section, Standards Development	Authorized by: Head of Department, standards
Signed:	Signed:
Date: 2015-10-09	Date: 2015-10-09

