



**THE KENYA POWER AND LIGHTING COMPANY LIMITED**

**SCADA SYSTEM EXTENSION**

**BIDDING DOCUMENTS FOR**

**Contract A37:**

**Design, Supply and Installation and Commissioning of  
SCADA System for Distribution Substations and Associated  
Telecommunications System**

**VOLUME 2**

<b>Part 2</b>	<b>Employer's Requirements</b>
---------------	--------------------------------

**October 2014**

# TABLE OF CONTENTS

---

<b>TABLE OF CONTENTS</b>	<b>ii</b>
<b>LIST OF TABLES</b>	<b>v</b>
<b>LIST OF DIAGRAM</b>	<b>vi</b>
<b>ACRONYMS</b>	<b>vii</b>
<b>CHAPTER ONE</b>	<b>1</b>
<b>1 General Project Information and scope</b>	<b>1</b>
1.1 Project Scope	1
1.2 Project Area	6
1.3 General information on Technical Requirements	6
1.3.1 Work on Live Substations	6
1.3.2 Installation	7
1.3.3 Testing and commissioning	7
1.3.4 On the Job Training	8
1.4 Control, Monitoring and Telecommunication Equipment	8
1.4.1 General	8
1.4.2 Control panels, cubicles and racks	10
1.4.3 Power supplies and fusing	13
1.4.4 Indicators	15
1.4.5 Electronic equipment	16
1.4.6 Switches and relays	16
1.4.7 Measurement of electrical parameters	17
1.4.8 Wiring, cabling terminals	17
1.4.9 Labeling	17
1.4.10 Painting	18
1.5 Documentation and Drawings	19
1.5.2 Bid Drawings	20
1.5.3 Progress Plans	21
1.5.4 Exchange of Interface Information	21

1.5.5	Final Documentation	22
<b>CHAPTER TWO</b>		<b>23</b>
<b>2</b>	<b>RTUs &amp; ADAPTATION WORKS OF SUBSTATION</b>	<b>23</b>
2.1	Existing data acquisition system	23
2.1.1	Existing Teleinformation Plan	24
2.1.2	New RTUs	26
2.1.3	New Remote Terminal Units (RTUs) and Adaptation Works at Substations	35
2.1.4	Guaranteed Technical Particulars	58
2.2	Integration of the new stations to the SCADA/EMS system	63
2.2.1	General Information	63
2.2.2	Data Population	63
2.2.3	RTU and SCADA tests	64
2.3	TRAINING	65
<b>CHAPTER THREE</b>		<b>66</b>
<b>3</b>	<b>TELECOMMUNICATIONS</b>	<b>66</b>
3.1	FIBER OPTIC LINKS	66
3.1.1	GENERAL	66
3.1.2	FIBER OPTIC CABLE SPECIFICATIONS	69
3.1.3	FIBER OPTIC TOOLS & TEST EQUIPMENT SPECIFICATIONS	82
3.1.4	THE FIBER OPTIC TERMINAL EQUIPMENT SPECIFICATIONS	87
3.1.5	THE FIBER OPTIC CABLE & TERMINAL EQUIPMENT SPARES REQUIREMENT	97
3.1.6	TESTING	97
3.1.7	TRAINING	98
3.2	RADIOS	98
3.2.1	THE TECHNICAL SPECIFICATIONS	98
3.2.2	NEW INSTALLATIONS	101
3.2.3	COMMUNICATION TOWERS	103
<b>CHAPTER FOUR</b>		<b>108</b>
<b>4</b>	<b>48 VDC CHARGERS AND BATTERIES</b>	<b>108</b>

4.1	GENERAL REQUIREMENTS	108
4.2	DETAILED TECHNICAL SPECIFICATIONS	109
4.2.1	GENERAL REMARKS	109
4.2.2	SCOPE	109
4.2.3	RECTIFIER/ BATTERY CHARGER	109
4.2.4	BATTERY	118
4.2.5	D.C. CONTROL AND DISTRIBUTION BOARD	122
4.2.6	METERING AND MONITORING SYSTEM	123
4.2.7	ENCLOSURE	126
4.2.8	MANUALS, DRAWINGS AND MAINTENANCE SOFTWARE	127
4.2.9	SPARE PARTS	128
4.2.10	WARRANTY	128
4.2.11	TRAINING	128
4.2.12	TESTS	128
4.2.13	APPLICABLE STANDARDS	132
4.2.14	SCHEDULES	134

# LIST OF TABLES

---

Table 1-1 Summary of scope.....	3
Table 2-1 Distribution of monitored stations .....	23
Table 2-2 Type of alarms per bay in substations .....	30
Table 2-3 Number of alarms per voltage levels .....	32
Table 2-5: Existing RTUs in the scope .....	37
Table 2-6 Guaranteed Technical Particulars .....	58
Table 3-1 Estimated Distances.....	71
Table 3-2 Distribution of ODF's.....	75
Table 3-3 .....	77
Table 3-4 General Specifications for ODF .....	79
Table 3-5 .....	80
Table 3-6 Technical Specifications for Splicing Machine .....	83
Table 3-7 Minimum requirements for Fault Locator .....	85
Table 3-8 Proposed Link Equipment .....	87
Table 3-9 Guaranteed technical particulars (multiplexer).....	91
Table 3-10 Guaranteed technical particulars (Switch).....	93
Table 3-11 .....	96
Table 3-12 .....	97
Table 3-13 Radio Details .....	101
Table 3-14 Link Details .....	102
Table 3-15 .....	106
Table 4-1 Guaranteed Technical Specifications .....	134
Table 4-2 List of 48V Battery Chargers .....	149

# LIST OF DIAGRAM

---

Figure 3-1 SCADA, DATA & Telephony Integration.....	90
Figure 4-1 Fig. 4.2.3.9.1:.....	115
Figure 4-2 .....	116

## ACRONYMS

---

SCADA/EMS – Supervisory Control and Data acquisition/Energy Management system

KPLC - Kenya power and Lighting Co. Ltd.

RTU – Remote terminal unit

SAS – Substation automation system

# CHAPTER ONE

---

## 1 General Project Information and scope

### 1.1 Project Scope

This Part of the Specification describes the SCADA and Telecommunication System to be supplied to the Kenya power and Lighting Co. Ltd. (KPLC) for distribution and selected transmission stations. Each bidder is encouraged to propose its standard system to the extent possible, as long as it meets or exceeds the requirements of this Specification.

New and existing RTUs including all necessary interfacing to the substation equipment are to be installed or extended at 58 selected Substations of the Kenya Power and Lighting Co. Ltd. (KPLC). The existing RTUs need to be expanded to cater for additional data requirement from the sub-stations. The details are captured in chapter 2 of this specification.

The Telecommunication system to be supplied under this contract shall satisfy KPLC's communication requirements for operational purposes that is; operational telephony and SCADA / EMS data transmission. The telecommunication system to be provided shall consist of fibre optic and radio links together with all telephone and data transmission equipment required as described in Chapter 3 of this Specification. The power supply for both SCADA and Telecommunications equipment is also captured in chapter 4 of this specification.

The Project covers the design, manufacture, testing, supply, insurance, packing for export, shipment, delivery to site, unloading, complete erection, testing on completion, commissioning for the SCADA and Telecommunication Systems for the distribution stations.

In particular the project comprises:

- (i) installation of all equipment and works necessary to interface the controls, indications, alarms, measurement and metering data from the substations to the SCADA / EMS system.



- (ii) Integration of all the station RTUs to the existing KPLC's central SCADA/EMS system
- (iii) Establishment of telecommunication network for transmission of SCADA data and speech using fibre optic and UHF / VHF radio communication links.
- (iv) Installation of a complete 48V dc power supply system that serves both SCADA and communication systems per station.
- (v) Training on SCADA equipment, telecommunications equipment's.
- (vi) Provision of Spares, Tools & Test Equipment, As built documentation and other facilities for project management as described in the detailed specifications.

## 1.2 Project Timelines

The project is expected to be completed in 18 months from inception. In order to maximize on the project benefits, all the Substations in all Lots, where the whose SAS/RTU have been installed and locally tested under other projects and communication media, namely fibre has already been installed, necessary Multiplexers/Switch shall be commissioned within Six (6) months of contract effectiveness.

## 1.3 Project LOTS

The project is divided into three lots namely:

1. **LOT 1:**Design, Supply and Installation and Commissioning of SCADA System for Distribution Substations and Associated Telecommunications System for Nairobi and Mt. Kenya Regions
2. **LOT 2:** Design, Supply and Installation and Commissioning of SCADA System for Distribution Substations and Associated Telecommunications System, for Coast Region.
3. **LOT 3:**Design, Supply and Installation and Commissioning of SCADA System for Distribution Substations and Associated Telecommunications System, for West Kenya Region.

**Table 1-1 Summary of scope**

**Signal list Totals**

Region	Station	Indications	Alarms	Commands	Measurands	Energy Meter Inputs	Telecomms solution	ADSS approx Length (km)	Scada Installation	Telecomms Installation	Existing Scada in station
<b>Nairobi</b>	<b>LOT 1</b>										
1	Doonholm 11kV						Fiber to Nairobi South with switches		No	yes	Siemens SAS
2	Industrial 66/11kV	29	107	21	42	36	Fiber to Nairobi South with switches	8	yes	yes	RTU 560
3	Karen 66/11kV						Replace Radio with Mux		No	yes	
4	Kikuyu 66/11kV	26	78	21	43	20	Radio to Ngong Hills		yes	yes	RTU 560
5	Limuru 66/11kV	8	18	4	4	2	Install MUX		yes	yes	Siemens SAS
6	Athi River ss 33/11kV	16	49	8	21	6	Install MUX		no	yes	
7	Machakos 33/11kV	16	49	8	21	6	Intsall FO Switches		yes	yes	
8	Nairobi Airport 66/11kV	30	101	18	43	26	Fiber to Embakasi with switches		no	yes	Siemens SAS
9	Nairobi West 66/11kV	48	174	22	88	40	Fiber to Embakasi available		yes	yes	RTU 560
10	Nyaga 33/11kV	18	28	13	30	2	Fiber to Ruiru with switches	20	yes	yes	
11	Muthurwa	52	179	31	92	42	Intsall Switches		no	yes	Siemens SAS
12	Steel Billets	24	88	15	25	4	Radio to Juja		yes	yes	
13	EPZ	24	96	12	16	4	Install FO switche		yes	yes	RTU 560
14	Mai Mahiu	24	128	18	24	4	Install MUX	30	Yes	Yes	
<b>Mount Kenya</b>											
1	Embu East						Install FO Switches		no	Yes	SAS Exists
2	Embu 33/11 kV	22	83	15	36	20	Install FO switches & FO	25	yes	Yes	
3	Karatina 33/11 kV	30	69	13	31	16	Fiber to Kiganjo with switches	20	yes	Yes	
4	Kerugoya 33/11 kV	13	35	6	16	10	Fiber to Karatina with switches	20	yes	Yes	
5	Nanyuki 33/11 kV	14	42	7	20	10	Fiber to Nanyuki 132 Installed		yes	Yes	
6	Ndarugu 33/11 kV	11	34	5	19	8	Install fibre from Mangu & switches	10	yes	Yes	

7	Meru 33/11 kV	19	65	12	32	16	Install FO switches		yes	Yes	
8	Othaya 33/11 kV	26	65	12	29	14	Fiber to Ruringu with switches		yes	Yes	
9	Githambo 33/11 kV	11	34	5	19	8	Fiber to Githambo 132kV with FO switches	10	yes	Yes	
10	Kiganjo 33/11 kV	22	61	11	27	12	Radio to Kiganjo 132kV	7	yes	Yes	Expand Existing RTU 560
<b>LOT 2</b>											
<b>Coast</b>											
1	Msambweni	12	24	10	13	2	Fiber from Mwambungo	20	yes	yes	
2	Mwabungo 33/11kV	10	22	9	13	2	Fiber to Galu 132kV	5	yes	yes	
3	Rabai Bamburi						Fibre to Rabai + Mux	35	No	yes	
4	Kanamai	8	22	8	10	2	Fibre From Bamburi	18	yes	yes	
5	Watamu	7	22	8	10	2	Fiber to Malindi 132kV	25	yes	yes	
6	Kaloleni 33/11kV	6	14	7	9	2	ADSS + switches	30	yes	yes	
7	Malindi 33/11kV						Install MUX		no	yes	
8	Utange 33/ 11 kV SS	10	24	9	12	2	Fibre From Bamburi + FO switches	12	yes	yes	
9	Shanzu 33/ 11 kV SS						Fibre From Bamburi - Kanamai line	5	No	yes	Areva
10	Mbaraki	40	118	24	26				yes	no	RTU 560
11	Mwatate 33/ 11 kV	10	24	9	12	2	Fibre From Voi + FO switches	20	yes	yes	
<b>Western Kenya LOT 3</b>											
1	Kakamega 33/11kV	20	50	20	24	0	Install MUX		yes	yes	
2	Kericho 33/11kV	23	65	12	32	16	Fiber to Chemosit with Mux	20	yes	yes	
3	Kisian 33/11kV	16	42	7	25	14	Fiber to Obote road with FO switches	15	yes	yes	
4	Kisii 33/11kV	27	99	19	43	30	Fiber to Kegati available.need switches		yes	yes	
5	Kisumu East 33/11kV	25	73	14	33	16	Fiber to Kisumu 132 kV with FO switches	10	yes	yes	
6	Mogogosiek 33/11kV	24	69	13	31	14	Radio to Chemosit		yes	yes	
7	Obote Rd 33/11kV	28	107	21	42	32	Fiber to Kisumu 132 available		yes	yes	
8	Sotik 33/11kV	12	38	6	18	8	Radio to Chemosit		yes	yes	
9	Cheptulu 33/11kv	9	33	8	13	0	Radio to Kakamega	20	yes	yes	

10	Elburgon 33/11kV	9	25	7	15	10	Fiber to Soilo	10	yes	yes	
11	Gilgil 33/11kV	12	30	6	14	12	Install MUX		yes	yes	
12	Marula 33/11kV	27	68	18	22	0	Radio to Naivasha 132	6	yes	yes	
13	Kihoto SS 33/11kV	14	32	6	12	0	Radio to Naivasha 132	10	yes	yes	
14	Soilo	37	73	29	14	16	Install MUX		yes	yes	
15	Nakuru Depot 33/11kV	29	119	35	43	0	Existing		yes	no	
16	Njoro 33/11kV	12	22	8	12	0	Fiber to Soilo	15	yes	yes	
17	Nyahururu 33/11kV	26	60	18	22	0	Fiber to Rumuruti		yes	yes	
18	Rongai 33/11kV	10	27	6	10	6	Fiber to Soilo	5	yes	yes	
19	Mwariki 33/11kV	6	24	6	8	8	Fiber to Nakuru depot	5	yes	yes	
20	Eldoret Depot 33/11kV	29	119	35	43	0	Mux required		yes	yes	
21	Eldoret Industrial 33/11kV	25	99	19	37	26	Fiber to Eldoret 132	8	yes	yes	
22	Kitale 33/11kV	20	30	10	18	4	ADSS FO & switch	20	yes	yes	
23	Kisumu 132	10	21	5	10	4			yes	no	Expand existing RTU 560
24	Kapsabet 33/11kV	12	38	6	18	8	FO Switch		yes	yes	
25	Turkwel 11/220kV	18	81	8	15	2	Install power line carrier		Yes	Yes	RTU 560
<b>Total</b>		<b>1024</b>	<b>3145</b>	<b>675</b>	<b>1317</b>	<b>540</b>		<b>414</b>			<b>0</b>
<b>25 % spare signals capacity</b>		<b>256</b>	<b>786</b>	<b>169</b>	<b>329</b>	<b>135</b>					
<b>Total Signals</b>		<b>1280</b>	<b>3931</b>	<b>844</b>	<b>1646</b>	<b>675</b>					

## 1.4 Project Area

The KPLC SCADA system is implemented into four main regions of operations. These are Nairobi, Coast, West Kenya and Mount Kenya regions.

The National Control Centre and the Regional Control Centres host the main SCADA system for which the RTUs shall be connected to.

The control centres are: National Control Centre (NCC) in Nairobi, West Regional Control centre (WRCC) at Lessos, Coast Regional Control Centre ( CRCC) at Rabai, Mt. Kenya Regional Control Centre ( MRCC), at Kiganjo.

The stations under the scope are spread out to all the KPLC operational regions as listed in

### Table 1-1 Summary of scope

## 1.5 General information on Technical Requirements

### 1.5.1 Work on Live Substations

Work is to be done on substations in operation; therefore, the following factors are of paramount importance:

- (i) Minimization of outage time
- (ii) Adaptation to operational constraints. All work must be planned with this in mind. The Contractor shall adhere to all instructions and safety rules approved by the Government and the Employer and must strictly follow all instructions from the Employer's supervisory personnel on safety, health and environmental issues.
- (iii) The Contractor shall appoint his Project Manager/Technician who will be **authorized to receive work permits at the work sites** as required by KPLC safety rules. All outages shall be discussed with the Employer and the Project Manager at least 14 days before the outage is required. No work shall start before Employer's site manager has authorized the work, established the required earthing and marked the safe area. All switching on live parts shall be done by the Employer. The Contractor and his personnel must respect the physical constraints as well as constraints for scheduling set by these circumstances. However, the Employer will make all reasonable effort making the work conditions and the scheduling as efficient as possible for the Contractor.

If physical constraints make it necessary to replace cabinets needed for operation, the Contractor must as far as possible erect and connect the new cabinets temporarily adjacent to the one in operation. A quick disconnection and removal of the old cabinets can then be performed and the new cabinets pulled in with most of its cables already fitted. Location of new cabinets shall be approved by the Project Manager and a proposal for such shall be given by the Contractor one month prior to erection.

### **1.5.2 Installation**

The Contractor shall carry out installation, testing at site and commissioning of the equipment specified in the Specifications. All work, methods of work and workmanship, whether fully specified herein or not, shall be of the highest order in all respects; the generally accepted requirements and commonly recognized good practice for first-class work of this nature are to be adhered to.

The Contractor shall provide all staff, such as engineers, supervisory staff, skilled and unskilled labour necessary to carry out and complete the Contract Works on schedule as specified. Information regarding site staff shall be shown in the relevant Schedule.

The Contractor shall provide all vehicles, installation, tools and equipment necessary to carry out the Contract Works, including personnel transport..

### **1.5.3 Testing and commissioning**

Testing at site shall be carried out by experienced testing/commissioning engineers approved by the project manager. Functional tests shall be inherent in all test procedures. The Contractor shall record the test results in an approved test form in such a manner that the test reports can be used as the basis for future maintenance tests. Test methods and equipment shall be noted on the test sheets. The test protocols shall be submitted to the project manager in advance for approval.

A complete test report in 4 sets shall be handed over to the Project Manager not later than one month after the equipment being commissioned. The test engineers shall at site keep a complete record of correction made during testing and one set of corrected drawings shall be kept at site after commissioning and one set handed over to the Project Manager.

Commissioning shall be carried out by the Contractor in the presence of the Employer's engineers and the Project Manager.

Once the pre-commissioning tests are complete, the testing engineer shall submit all the preliminary tests reports for review. The tests shall be accompanied with a complete procedure for energizing and loading of the equipment. The procedure shall include; a detailed commissioning schedule showing the sequence to follow step by step in all connections, including control of phase sequence (where applicable) and other pertinent factors. Switching of energized components will be performed by the Employer.

#### 1.5.4 **Training**

Training as detailed in the specifications shall be provided by the Contractor. The scope of training shall be subject to the Project Manager approval. As part of knowledge transfer, **On The Job Training** where the Employer's staff shall be availed necessary participation for purposes of knowledge transfer during the entire project duration.

### **1.6 Control, Monitoring and Telecommunication Equipment**

#### 1.6.1 **General**

This Section is valid for the design of the control, monitoring and telecommunication equipment and as far as applicable for interfaces.

Only requirements for technical performance of the equipment are stated here, whilst the detailed requirements of the tasks to be performed by the RTU and Telecommunications systems and the scope of delivery for each individual item of plant is stated in the technical Specifications.

The requirements are to be strictly observed with regard to design and execution.

The equipment to be provided shall be suitable for faultless and safe control and supervision of the entire station during all phases of operation.

As a general rule, measuring points and measuring equipment, status indications and alarms for interlocking, protection and local annunciation purposes shall be separate and not be combined

with SCADA / EMS equipment for supervisory control, status indication and alarm acquisition, measurement and metering data acquisition. Signals to be processed in several systems, e.g. remote, local and logic controls, local indication, event recording system etc. shall be suitably repeated and mutually decoupled to avoid interaction.

The material of all equipment shall fully meet the requirements regarding safety and operational conditions of the media to be measured. Instrument piping to transmitters and sample piping shall be of stainless steel.

All the equipment shall be suitable for the location in which it is to be mounted and in particular all outdoor equipment shall be suitable for the climatic conditions of the site.

The external finish of cubicles shall be non-reflective and in the color to be approved by the employer.

Cable entry shall be through gland plates in the base and the top of the cubicles, the use of the latter being subject to the Owner's approval. Cable entries shall be protected against insects and rodents.

All locks to telecontrol and telecommunications cubicles delivered under this Contract shall be provided with a master key system.

The design of the equipment and cubicles shall be made in such a way that maintenance, such as troubleshooting, regular maintenance, replacement of defective units, putting into use of redundant units, etc. can be carried out as safely as possible. This requires that;

- Readily accessible test and /or break points to facilitate fault isolation. The placement of components shall allow access for test probes and connectors.
- Suitable grips or handles to facilitate the safe removal and installation of heavy or bulky units.
- Physical provisions to precluded interchange of units or components of a similar form that is not in fact interchangeable.
- Physical provisions to preclude improper mounting of units or components.
- Provisions (e. g. labels) to facilitate identification and interchange of interchangeable units or components.



- Measures to ensure that identification, orientation and alignment provisions include cables and connectors.
- Sensitive adjustment points should be located or guarded so that adjustments will not be disturbed inadvertently.
- Internal controls should not be located close to dangerous voltages. If such location cannot be avoided, the controls should be appropriately shielded and labeled.
- Accessible points under voltage shall be located in such a way that inadvertent short circuits during mounting, installation or maintenance work are prevented.
- Pre-set controls requiring routine adjustment shall be accessible with the complete equipment and adjacent equipment in operation.

#### 1.6.2 **Control panels, cubicles and racks**

Panels, cubicles and marshaling racks shall generally be free standing and shall be constructed of folded sheet steel of adequate thickness to provide rigid support for the control and monitoring equipment which shall be mounted thereon.

Panels shall be mounted on channel base frames which shall provide a toe recess. Panels and cubicles designed for personnel access shall be provided with metal floors and shall be suitably ventilated. Doors shall be provided with a lock which may be opened by a person within the panel without the use of a key. It shall be possible to open all panels associated with one unit by the use of one master key. Adequate lighting and power points for hand tools shall also be provided.

The overall height of cubicles and racks housed in the relay room shall not exceed 2.20 m and the color shall be subject to the approval of the Project Manager/Employer.

All instruments and control devices shall be easily accessible and capable of being removed for maintenance purposes.

Cable connections to panels and cubicles shall be equipped with suitable seals so as to prevent the ingress of dust or vermin or the propagation of possible fires. During installation, a provisional sealing of cable penetrations is required.

### **1.6.2.1 Cubicles**

In the relay rooms all equipment for voltages exceeding 60 V is to be accommodated in separate cubicles or is to be installed within the cubicles in such a way that a clear separation is achieved and separate connection terminals are used.

Cubicles which are installed in non air-conditioned rooms shall be provided with thermostatically controlled heating elements. Each thermostat shall have an adjustable set point which shall be adjusted during the commissioning period to such a value that no moisture shall occur on the equipment and during periods of high ambient temperature the temperature rating of the equipment is not exceeded. Subject to the Project Manager's approval, the general design should be as follows. Other solutions are subject to the Project Managers approval.

- The electronic equipment shall consist of plug-in modules, mounted in 19" or CEPT slim racks. Empty slots shall be covered with dummies.
- The cubicles shall be equipped with hinged frames to which the 19" racks are assembled.
- Other equipment, such as terminal blocks shall be mounted on a mounting plate in the rear of the cubicle.
- The opening angle of the door and the hinged frame shall be at least 120 degrees in order to have good access to all equipment in the cubicle.
- The cabling/wiring from the hinged frame to the other equipment in the cubicle shall be adequately protected and of sufficient length and flexibility.
- The cubicles shall be equipped with cubicle lighting.
- The cubicles shall be dust-free.
- Each cubicle shall be labeled. The labels shall be clear and durable.
- The cubicles shall be free-standing cubicles.

The anti-corrosion treatment and painting of the cubicles shall be in accordance with the specified environment and shall be described in the offer.

### **1.6.2.2 Marshaling racks**

Closed type racks are to be used for the marshaling and termination of low voltage control cables. These shall be constructed of rigid, angle section steel. Upon completion of terminations

open type marshaling racks shall be enclosed by sheet-metal covers. Main Distribution Frames (MDF) shall form the marshaling interface as follows:

- At substations, between the various telecommunications equipment and between the telecommunications equipment and the telecontrol RTU/SAS.

The MDFs shall be cubicles complying with the construction requirements, as specified elsewhere. They shall provide the following facilities:

- a clear boundary between various equipment
- easy fault localization
- a clear test point
- optimal cabling arrangements on both sides
- installation of various systems can be done at different times

Method of terminating wired shall be proposed in the Tender. The number of terminals shall include 50% spare.

### **1.6.2.3 Terminal boxes**

In order to simplify local collection of cables, distribution of signals and to centralize connections in the plant terminal boxes or, wherever suitable, terminal cabinets shall be foreseen. The necessary intermediate terminal boxes and cabinets shall be equipped with the necessary terminal strips, cable glands and attachment components for the connection of the cables. The necessary earthing terminals shall be provided for the earthing of the boxes and cabinets.

### **1.6.2.4 Ventilation**

Heat dissipation of cubicle mounted equipment shall be kept as low as possible. The average heat dissipation per typical cubicle and the temperature rise inside the cubicle from the maximum ambient temperature shall be stated in the Tender.

Components generating a lot of heat shall be adequately spaced from their mounting boards and from other components.

Natural cooling is preferred. The approval of the Project Manager must be obtained in all cases where it is intended to incorporate forced cooling.

If the use of forced cooling cannot be avoided, means shall be provided for indicating and alarming any significant reduction in air flow, and the equipment shall be so protected that no damage occurs due to failure of the forced cooling. The full requirements of the performance specification shall be maintained until the protective device operates. The Bidder shall state how long the equipment can remain in operation at maximum ambient temperature without forced cooling. Air blown through equipment for cooling shall first be passed through an efficient dust filter. Multi-stage filters, arranged to permit individual filters to be removed for cleaning are preferred.

The cubicles shall be equipped with high temperature alarm (lamp and potential-free closing contact). The alarm shall be connected to the RTU.

### **1.6.3 Power supplies and fusing**

All monitoring and control equipment inside the substations shall preferably be connected to the system.

The contractor must ensure however, that plant mounted equipment is not adversely affected by the long cable runs, particularly to the more distant units.

If the Contractor needs a different voltage level, he shall design, supply and install all the necessary equipment including battery, battery charger, busbars etc. for this system.

The main power supply fuses shall be located in functional groups within separate power distribution cubicles.

Fuse ratings and time characteristics shall be such that in all cases a fault within an individual item or module will cause the fuse associated with that item, to rupture and thus disconnect that item from the power supply, before the main fuse is affected.

Failure of a main fuse shall affect the overall operation of the plant as less as possible.

Failure of a main control fuse shall be indicated in the control area by means of an alarm. This alarm shall state the identity of the failed main fuse.

Failure of an individual module or component fuse shall be indicated by a general alarm which shall state the cubicle type in which the fuse has failed and an individual signal in the respective control module shall be initiated.

The design of the electrical power supplies and fusing system shall ensure that any faults in modules or other devices, which may block sequence logic interlocks, automatic control systems or other control systems are restricted to the system in which the fault has occurred.

All electronic devices shall be protected against transient voltage levels which would otherwise damage the device.

Drive command modules or devices which take over their function must be separately fused.

Interlocks and protection logics for drives can be fused together with the drive command module if these logics are used only for the particular control circuit of the drive concerned. Otherwise they must be fused with the logic of the associated sub-group.

Lamp amplifiers for status indications, alarm indications and criteria call-up (non-fulfilled control criteria) shall be fused in groups independently of the logic equipment.

Binary signal conditioning and analog limit value modules should be fused separately, but may also be fused with the corresponding drive control of the drive control level as long as the signals are used only for remote and logic controls (interlocking, protection) of the drive concerned.

When a binary transmitter or limit value is used for several drives or groups the fusing shall be effected separately or be subdivided into logical groups so that any fault arising is confined as far as possible to a drive or group.

All measuring circuits shall be separately fused. If the analog signal will be distributed by analog signal conditioning and distribution modules, the fuses shall be located on these modules.

If analog signal distribution and limit value modules functions are arranged physically adjacent to one another, the limit value modules can also be fused with the corresponding measuring circuit.

All closed-loop circuits, including their drives and thyristor controllers, if any, shall be fused separately, but if the control circuit fuse fails, the capability of controlling the drive manually shall be retained.

#### 1.6.4 Indicators

All indicators mounted on control desks and panels shall be flush mounted. The minimum size for indicators mounted on the various sections of the panels shall be:

- non-urgent indicators                      96 x 96 mm
- important indicators                      144 x 144 mm
- mimic diagrams preferably              48 x 48 mm

The minimum accuracy tolerance for these indicators shall be 2.5% of span. Indicators shall generally be of the moving coil type but electronic type digital indicators are also acceptable. Where digital indicators are used these shall be provided with at least 4 digit indications.

Indicators mounted on local gauge boards shall be of circular type and shall have a minimum case diameter of 100 mm, preferably 160 mm. All local indicators shall be housed in robust dust and moisture proof cases suitable for open air installation. The read-out window for indicators, recorders and similar equipment shall be non-reflecting, anti-static and minimize parallax errors.

All control instruments shall be rectangular or square type, with the exposed metal portions of all cases having the same finish, trim and general appearance. Instrument and meter scales shall be white with black markings. Instrument cases shall be dust- proof.

Each instrument shall have a zero adjustment device so that the zero position of the pointer can be adjusted without removing the cover. For frequency measurement purposes it is not permissible to use reed type frequency meters except for the synchronizing equipment.

### 1.6.5 **Electronic equipment**

Where possible, plug-in type printed circuit boards shall be used.

External connections to the boards shall preferably be by plug and socket connection.

All electronic components, including integrated circuits, transistors, resistors, capacitors and inductors shall be selected in order to ensure long life and stable operation. Indication lamps used in conjunction with electronic circuits shall preferably be light emitting diodes.

All relay equipment shall use modern plug-in type circuit boards, containing standard type miniature relays, which can be plugged- in and easily replaced on sockets on the circuit boards. Only a few types of standard relays shall be used. All relays shall be of the encapsulated type. External connections to the boards shall preferably be by plug and socket connection.

For time relays transistorized relays will be preferred. Time-setting shall be effected preferably by means of setting knobs on the front panel.

### 1.6.6 **Switches and relays**

Switches mounted in the control panels shall be of the miniature or sub-miniature type.

The function of the pushbutton shall be clearly shown. Discrepancy switches or pushbuttons shall be provided for the operation of switchgear and the initiation of drives. Discrepancies between the switch position and the plant state shall be indicated by an integral light which shall illuminate the switch in a flashing mode of operation.

Indicating instruments having maximum and/or minimum contacts shall not be used for any main system. All surfaces used for electrical contacts shall be silver, gold or silver alloy. If the Contractor wishes to use other metals he shall give clear reasons.

The connection between low-voltage electronic control circuits and power circuits shall consist of interposing relays for linking the two systems. All relays have to be of the encapsulated type.

### **1.6.7 Measurement of electrical parameters**

Remote indicators for electrical quantities such as power, voltage, current frequency, etc. will be of the milliamp type .

Solid state electronic type transducers will then be provided to convert the output of current and voltage transformers into an impressed direct current in the range 0 – 20 mA or 4 – 20 mA.

### **1.6.8 Wiring, cabling terminals**

In particular wiring within panels etc. shall be supported on trays and shall be segregated according to voltage level. Wiring carrying A.C. and D.C. voltage shall also be segregated.

All panels, cubicles and racks shall be factory wired. Where they must be supplied in more than one section, electrical connections between the sections shall be via terminal strips provided for this purpose.

Spare cores shall be terminated at terminal strips in such a way so as to give a maximum length of core and shall be ferruled in such a way so as to indicate that they are spare cores.

Terminal strips at the transmitters shall be of the screw type. Screw type terminals shall have a metal insert between screw and conductor. In electrical, relay and control rooms advanced semi-automatic connection techniques, like terminal point, wire-wrap are preferred. Wire wrap and terminal point connections shall be performed using an approved semi-automatic or automatic, power operated hand tool.

Terminal strips within panels shall be set at an angle to afford easy identification and access.

### **1.6.9 Labeling**

The identification and lettering of scales dials and inscription, i.e. name-plate labels, etc. shall be in English.

The metric system shall be used for all scales according to the ‘General technical requirements’.



The Contractor shall supply all labels, nameplates, instruction and warning plates necessary for the identification and safe operation of the individual equipment and the plant and all inscriptions shall be in the English language.

The identification and classification of all measuring points must be shown on diagrams to be produced by the Contractor and entered in the respective lists.

#### **1.6.10 Painting**

However, panels, cubicles, control equipment and marshaling racks are to be supplied with the final painting, whereby external surfaces shall be semi-gloss.

Local mounted cubicles, housing control and monitoring equipment shall be protected against rust and corrosion by a protective coating such as galvanized zinc, which shall be applied as a first factory coat.

In all cases where site erection work exposes bare metal, such as the drilling or punching out of holes for cable or pipe entry, these areas shall be protected by the immediate application of a protective first coat similar to the original.

The shade and grade of paint are to be agreed to by the Project Manager and must harmonize with the overall architectural design.

Any machined or bright faces and parts which are not painted must be protected against corrosion by suitable agents prior to installation.

After completion of installation and commissioning, but before Taking Over the Contractor shall make good all marks, scratches and damage to the painted surface of all equipment supplied under this contract irrespective of the cause.

The Contractor shall also take every reasonable precaution to prevent damage to panels and cubicles during the course of erection and commissioning. Repairs to panel and cubicle paintwork shall be carried out in such a way so as to restore the equipment to its original factory condition and shall be to the satisfaction of the Project Manager.

## **1.7 Documentation and Drawings**

### **1.7.1.1 General**

The Contractor shall prepare and submit to the Project Manager for approval dimensioned general and detailed design drawings and other pertinent information of all equipment specified in the Bid Documents. Unless otherwise agreed the information shall be exchanged on paper.

Approval of drawings shall not relieve the Contractor of his obligations to supply the equipment in accordance with the Specifications. The Contractor is responsible for any errors that may appear in the approved documents. He shall as soon as an error has been detected, deliver the corrected documents to the Project Manager for re-approval.

If the equipment is to be connected to existing equipment the connection shall be documented in a coherent and overlapping way at least containing terminal identification in old equipment. Schematic diagrams shall contain complete loops within new and old equipment.

All text on documents provided by the Contractor shall be in the English language in addition, if necessary, to that of the country of origin. All drawings shall be dimensioned in millimetres.

The Contractor shall, during the total project time, maintain a List of Documentation to be updated by him whenever needed. The List of Documentation shall include the date of original issue of each document submitted as well as the dates of every revision. The List of Documentation shall also include a time schedule for the submittal of the documentation.

Symbols used for electrical equipment shall be in accordance with IEC 60617. The Contractor shall establish a coherent system for physical and functional reference designation in accordance with IEC61346. A similar systematic scheme shall be defined for cable numeration. These schemes shall be used throughout on the drawings and documentation and the designation shall be labelled on the components and cables.

In addition to what is stated in Conditions of Contract, the following shall apply:

- The sizes of all documents and drawings shall conform to the ISO standard, i.e.:

- A1 594mm x 841mm
- A2 420mm x 594mm
- A3 297mm x 420mm
- A4 210mm x 297mm
- Sizes larger than A1 shall be avoided. The schematic diagrams and, apparatus and cable lists shall be of size of A4 except for one original and possible transparency copies of schematic diagrams that shall be in A3. Scales to be used on the drawings shall be 1:10, 1:20, 1:40, 1:50 and multiples of this series.
- All drawings made special for this project including civil works drawings, mechanical drawings, layout drawings and circuit diagrams shall be compiled on a computer aided drawing system and as part of the as built documentation be handed over on a CD with a format readable in AutoCAD version 14 or another format to be agreed upon in addition to the paper copies.
- All drawings shall be bound in hard covers.

### 1.7.2 Bid Drawings

The Employer's drawings attached to the Bid Documents are of informative character. These drawings are intended to illustrate the basic requirements to be satisfied. It is the responsibility of the Contractor to prepare a detailed layout showing the manner in which the various items of equipment offered can be accommodated to best advantage within the available area.

The Contractor is at liberty to offer arrangements based on significantly different principles where it is considered that these offer economic or technical advantages. It is 20ynchroniz, however, that the main Bid should comply with the principles shown in the enclosed drawings, other arrangements being submitted solely as alternatives to the main offer.

Significant changes in the layouts caused by the Employer may warrant price adjustments. However, no adjustments will be applied for minor changes due to incorporation of the Contractor's equipment.

The Bidder shall in his Bid enclose overall drawings showing dimensions, main working principles, and internal components and fixing methods to a detail level allowing the Employer to evaluate the functionality and completeness of the plant and equipment.

The following specific drawings shall be enclosed with the Bid:

- Single Line Diagram for each station
- Room layout proposals for each station

### **1.7.3 Progress Plans**

The Progress Plans shall at least contain the following milestones:

- Essential information delivered from Employer
- Documentation for approval from Contractor to Employer
- Release of factory documentation
- Factory Tests
- Shipment
- Site ready for installation works
- Start installation
- Ready for pre-commissioning
- Ready for commissioning
- Taking over Submittal of final documentation

### **1.7.4 Exchange of Interface Information**

The Contractors shall in due time supply interface information to other sub-contractors where needed. The Contractor is in particular required to check that all foundations and fixations of his equipment is sufficiently dimensioned to meet the forces acting upon it. If the Contractor feels that he lacks such information from other contractors he is obliged to request such from the Project Manager. The Contractor cannot claim liability exemption for his own contractual responsibilities because of actions performed or omitted by other sub-contractors.

### 1.7.5 **Project Managers facilities**

The contractor shall avail transport facilities on the 24/7 basis for use by the Project Manager during the entire project duration for travelling to sites for supervisory of work. For communication purposes the contractor shall offer airtime equivalent to KES 15,000 monthly, during the entire project duration.

### 1.7.6 **Final Documentation**

The Contractor shall supply final “as built” documentation taking into account all changes done under Installation and commissioning.

The Contractor shall also deliver manuals for operation and maintenance. These shall at least contain the following information:

- Detailed description of the equipment, the individual components, relevant clearances, tolerances, allowable temperatures, settings etc.
- Descriptions of main principles including flow diagrams, single line diagrams, circuit diagram, connection diagram, cable schedules, software documentation etc.
- Operational instruction. These shall illustrate the operational sequences in a clear and concise way.
- Test and adjustment procedures containing instruction for test and adjustment of the equipment under operation, after inspection and maintenance
- Test reports
- Spare part lists
- Maintenance instructions split into:
  - Manuals for preventive maintenance indicating periodic inspections, cleaning, lubrication and other routine maintenance.
  - Repair manuals describing fault location, dismantling, re-assembly etc.

The documentation shall leave the operators and maintenance personnel in position to operate the plant in a safe and optimal way and to perform repairs usual to be done by such personnel. The Project Manager shall approve the manuals before final submission.

## CHAPTER TWO

---

### 2 RTUs & ADAPTATION WORKS OF SUBSTATION

#### 2.1 Data acquisition system

KPLC has an existing central SCADA system situated at the National Control centre, with regional control centres in Nairobi (NRCC), Lessos (WRCC), Kiganjo (MRCC) and Rabai (CRCC).

There are 123 stations currently being controlled and monitored by the SCADA system.

These sub-stations are categorized as Transmission and Distribution and their distribution is as follows:

**Table 2-1 Distribution of monitored stations**

<b>REGION</b>	<b>No. of Transmission Stations</b>	<b>No. of Distribution Stations</b>
NAIROBI REGION	7	34
Mt. KENYA REGION	12	6
WEST KENYA REGION	22	4
COAST REGION	13	10

The SCADA central system is an ABB AB product Network Manager Rel3.8.

The configuration is such that, all transmission and generating sub-stations are monitored and controlled from the national control Centre.

Most distribution stations are monitored and controlled from their respective regional control centres

### **2.1.1 Existing Teleinformation Plan**

The teleinformation plan defines the data (status indications, alarms, measurements, Energy meter readings) that are acquired by the SCADA system from the substations. It also defines the devices for which remote control from the Master stations is, or will be established.

The tele information plan for the existing SCADA system can be summarized as follows:

#### **2.1.1.1 Controls:**

At all substations equipped with RTUs, CBs and motorized Isolators are remote controlled.

The transformer tap changers of are remote controlled

Trip/Lockout relays are reset from respective control centres where applicable

#### **2.1.1.2 Status Indications:**

Status indications of circuit breakers, isolators and earthing switches are acquired via the RTUs/SAS at the substations and indicated at the Control Centres. ON and OFF positions for status indications are acquired independently allowing the detection of undefined positions.

Tap changer position indications are acquired from the transformers together with information of control selectors for “master / follower / independent” “manual /automatic” and “local / supervisory”.

#### **2.1.1.3 Alarms:**

Individual and grouped alarm messages are acquired from the RTU/SAS and transmitted to the corresponding RCC's and the NCC. Since the sub-stations are different in state and have equipment from different manufacturers, the alarms from each may have a slight variation.

#### **2.1.1.4 Measurements:**

Selected busbar voltages are acquired from the substations. Bus voltage acquisition does not always include all busbar sections at a substation

Selected active and reactive power as well as in some cases current measurements for overhead line feeders are acquired (bi-directional)

Selected active and reactive power and current for generators

Active and reactive power in selected transformer feeders (bi-directional)

Frequency at selected stations.

At the Control Centres the information is processed and displayed. The received measurement values are evaluated regarding upper or lower limit violation.

Further the direction of the energy flow is acquired and indicated at the Control Centres.

#### **2.1.1.5 Energy Metering**

Energy meter values (MWh) are transmitted from various stations to the NCC through SCADA.

For system operation daily analysis, control assistants take half-hourly readings (MW) from all stations through telephone and enter them into separate office LAN computer. These information is also available from reports that may be obtained from the historical servers of the SCADA/Ems system.

#### **2.1.1.6 Existing RTUs/SAS**

Different types of RTUs&/ SAS have been installed at various substations for data acquisition in the KPLC network. These are :

- Collector 400 RTU manufactured by ASEA (one station)
- RTU 560 manufactured by ABB.
- MicroSCADA substation Automation system manufactured by ABB
- CLP 500 substation Automation system manufactured by EFACEC, Portugal
- SICAM station manager manufactured by Siemens
- SAS manufactured by Crompton Grieves
- SAS manufactured by Conco,SA
- MicomC264 substation Automation system manufactured by Areva/Alstom
- SAS manufactured by Sprecher systems.

Most of the RTUs/SASs have some spare capacity with available expansion capabilities. For the stations under this contract that need expansion, the contractor shall utilize the available spare capacities and cater for the required expansion so that by end of project stations shall have a minimum of 10% spare capacity.



The existing RTUs/SAS are mostly double port RTUs using IEC 60870-5-101/104 transmission protocols to control centres.

Transmission stations are configured to communicate to the National control centre, as well as its appropriate regional control centre

Distribution stations are basically configured to communicate with its regional control centre

### 2.1.2 New RTUs

For supervisory control and acquisition of data, as defined in the teleinformation plan described below, the following equipment and works are required at the station level:

- New Remote Terminal Units (and/or expansion of the existing RTUs/ SAS)
- Interfacing Marshalling Cubicles ( extended where existing to accommodate all data points in station)
- Interface terminal blocks at the existing station control and protection panels or at the station equipment itself.
- Cabling between RTUs/SAS and the points where the required data are available (either marshalling cubicles or interface terminal blocks in existing control and relay panels at the stations)
- Wiring modifications and additional de-coupling relays
- Galvanic isolation of all signals from process to RTU
- Analogue and digital transducers (existing transducers to be used where available)

The control schemes of some circuit breakers at existing stations are not suitable for supervisory control due to missing synchrocheck relays and manual line/busbar VT selection for closing operation.

In such stations, additional synchrocheck relays and voltage selection logic have to be installed under the project. This applies for stations where separated networks / generation could be switched under none-synchronous conditions.

### **2.1.2.1 The Teleinformation Plan**

Based on the present and future functional requirements, the Contractor shall consider and implement the following teleinformation plan for the SCADA in stations:

#### **2.1.2.1.1 Control of circuit breakers and isolators**

Supervisory control of all 33 kV, and 11 kV Circuit Breakers (CBs) as well as selected 220kV, 132 kV and 66 kV CBs

- Supervisory control of all 33 kV and 11 kV as well as selected 220kV, 132 kV and 66 kV 27ynchroni line and busbar isolators.
- Remote reset of master –trip relays
- Remote control of master-follower- Independent and Manual –Auto selection for Tap Changers

#### **2.1.2.1.2 Voltage control / voltage regulation:**

- Remote control of reactors (all voltage levels) and capacitors (11kV only). Control of the respective CBs is included above.
- Remote control of all on-load tap changers for all 33/11 kV, 66/11 kV, 66/33 kV transformers, as well as for selected 220/11kV, 132/11 kV and 132/33 kV transformers

#### **2.1.2.1.3 Status Indications:**

- Status indication of all 33 kV and 11 kV circuit breakers at substations equipped with RTUs supplied under this contract or already existing and require expansion. For acquisition of 11 kV, 33 kV, 66kV 132 kV and 220 kV CB status indications the auxiliary contacts of only one pole shall be wired for CB closed position and for open position.
- Status indication of all 33 kV and 11 kV line and busbar isolators as well as 220kV, 132kV and 66 kV isolators at selected stations equipped with RTUs supplied under this contract or already existing and require expansion. For 33 kV and 11 kV substations equipped with with-drawable CBs, the position of the CB (in switching position / withdrawn) shall be indicated instead.

- Position indication of on-load tap changers of all 66/11 kV, 66/33kV and 33/11 kV transformers, as well as selected 132/11 kV and 132/33 kV transformers.
- Status indication of “Local / Remote”, “Automatic / Manual” and “Master / Follower” mode of automatic voltage regulators where applicable

#### **2.1.2.1.4 Alarms:**

##### **2.1.2.1.4.1 Bay Alarms:**

For each bay, the following protection signals shall be acquired individually if available:

- “Main Protection 1 Trip” (MP1)
- “Backup Protection Trip” (BPT)
- “PT Fail “ (PTF)
- “Trip Circuit Faulty” (TCF)
- “Protection A Faulty” (PAF)
- “SF6 Low 1<sup>st</sup> Step (SF1)
- “SF6 Low 2<sup>nd</sup> Step (SF2)
- “CB Spring Charging Failure” (SCF)
- “Autorecloser Operated” (ARO)
- “Local Control Position of Selector Switch” (LCP)
- “CB Pole discrepancy protection” (CBD)

##### **2.1.2.1.4.2 Transformer alarms:**

- “Temperature Alarm” (TTA) oil and winding temperature as grouped alarm
- “Temperature Trip” (TTT) oil and winding temperature as grouped alarm
- “Buchholz Alarm” (TBA) tank and OLTC as grouped alarm
- “Buchholz Trip” (TBT) tank and OLTC as grouped alarm
- “Transformer Oil Level (Low and High)” (TOL)
- “Transformer Cooling fan Trouble” (TCT)
- “Transformer Bank out of Step” (TBS)

- “Transformer Bank Independent” (TBI)
- “Transformer OLTC Control/Supply Failure” (TCC)

#### **2.1.2.1.4.3 Busbars Alarms:**

- Busbar differential protection trip (BDT)

#### **2.1.2.1.4.4 Station alarms and warnings:**

- 110 V DC alarm (DA1)
- 110 V Battery Charger A Trouble (CA 1)
- 110 V Battery Charger B Trouble (CB 1)
- 48 V DC alarm (DA4)
- 48 V Battery Charger A Trouble (CA 4)
- 48 V Battery Charger B Trouble (CB 4)
- Protection Panel DC Supply Trip (PPS)
- Station Control Disabled (SCD)
- RTU alarm (RTU)
- Communication alarm (COM)

The different type of alarms to be acquired from each type of bay in the network substations is shown in **Table 2-2** below.

Whereas **Table 2-3** shows the number of alarms to be acquired from the bays for the different voltage levels

**Table 2-2 Type of alarms per bay in substations**

Type of Alarm	Line Bay	Trans-former Bay	Trans-former	Coupler Bay	Busbar	Station
Local / Remote	LCP	LCP		LCP		
Main Protection 1 Trip	MP1	MP1		MP1		
Back-up Protection Trip	BPT	BPT		BPT		
CB Pole Discrepancy	CBD	CBD		CBD		
PT Fail	PTF				PTA	
Trip Circuit Faulty	TCF			TCF		
Protection A Faulty	PAF			PAF		
SF6 Low 1 <sup>st</sup> Step	SF1			SF1		
SF6 Low 2 <sup>nd</sup> Step	SF2			SF2		
CB Spring Charging Failure	SCF	SCF		SCF		
Autorecloser Operated	ARO					
Circuit Breaker Faulty	CBF	CBF		CBF		
Temperature Alarm			TTA			
Temperature Trip			TTT			
Buchholz Alarm			TBA			
Buchholz Trip			TBT			
Transformer Oil Level (Low and High)			TOL			
Transformer Cooling fan Trouble			TCT			
Transformer Bank out of Step			TBS			

Type of Alarm	Line Bay	Transformer Bay	Transformer	Coupler Bay	Busbar	Station
Transformer Bank Independent			TBI			
Transformer OLTC Control/Supply Failure			TCC			
Busbar Differential Prot. Trip					BDT	
110 V DC alarm						DCA
110 V Battery Charger A Trouble						CA 1
110 V Battery Charger B Trouble						CB 1
48 V DC alarm						DCB
48 V Battery Charger A Trouble						CA 4
48 V Battery Charger B Trouble						CB 4
Protection Panel DC Supply Trip						PPS
RTU Alarm						RTU
Communication Alarm						COM

**Table 2-3 Number of alarms per voltage levels**

Type of Alarm	Line Bay	Trans-former Bay	Trans-former	Coupler Bay	Busbar	Station
220 kV Alarms	12	8	9	3	1	9
132 kV Alarms	12	8	9	3	1	9
66 kV Alarms	9	8	9	3	1	9
33 kV Alarms	7	8	9	3	1	7
11 kV Alarms	4	4	0	3	1	0

- Note: Voltage for transformers relates to high voltage side

**Measurements:**

- Busbar voltages (separate for each busbar and bus section) of all 66 kV, 33kV and 11 kV busbars and selected 132kV and 220kV busbars
- Frequency at each major power station and connection point to neighbouring countries
- Active / reactive power for  
All 220, 132, 66 kV and 33 kV line feeders (at both ends of the lines) and for the 11kV feeders  
All 220/11kV, 132/33kV, 66/11 kV, 33/11 kV, 66/33 kV transformers (at the high voltage and the low voltage side)
- generator feeders of selected Power stations
- Line current of each 11 kV feeders
- 48 V DC auxiliary voltages
- 110 V DC auxiliary voltages

**Energy Metering:**

- At all incomer feeders to the distribution network

### 2.1.2.2 Assessment of existing SCADA equipment at Substations

In order to perform the functions assigned to NCC and RCCs and to interface the controls, indications, alarms, measurements and meter readings to the SCADA/ EMS system,

- New RTUs have to be installed at several substations. As shown in the **Table 2.4** below
- In stations with existing RTUs/SAS, the additional data required from these stations, may 33synchro spare capacities of the existing RTUs installed/available at these stations.

To interface the new and/or additional data to be acquired and the controls to be executed to the RTUs/SAS, adaptation work in the control and monitoring schemes at the stations are required.

The table below shows the scope of stations to be done.

**Table 2.4** : Scope of RTUs and Data

Region	Station	Indications	Alarms	Commands	Measurements	Energy Meter Inputs	RTU AVAILABLE
<b>Nairobi</b>							
1	Industrial 66/11kV	29	107	21	42	36	RTU 560
2	Kikuyu 66/11kV	26	78	21	43	20	RTU 560
3	Limuru 66/11kV	20	30	15	10	4	Siemens
4	Machakos 33/11kV	16	49	8	21	6	
5	Nairobi West 66/11kV	48	174	22	88	40	RTU 560
6	Nyaga 33/11kV	18	28	13	30	2	
7	Steel Billets 66/11kV	24	88	15	25	4	
8	EPZ 66/33kV & 66/11kV	24	96	12	16	4	RTU 560
<b>Coast</b>							
1	Msambweni	12	24	10	13	2	
2	Mwabungo 33/11kV	10	22	9	13	2	
3	Kanamai	8	22	8	10	2	
4	Watamu	7	22	8	10	2	
5	Kaloleni 33/11kV	6	14	7	9	2	
6	Utange 33/ 11 kV SS	10	24	9	12	2	
7	Mbaraki 33/11kV	40	118	24	26		RTU 560
8	Mwatate 33/ 11 kV SS	10	24	9	12	2	
<b>Mount Kenya</b>							
1	Embu 33/11 kV	22	83	15	36	20	





### 2.1.3 New Remote Terminal Units (RTUs) and Adaptation Works at Substations

This Specification describes the new Remote Terminal Units (RTUs) to be supplied to KPLC as part of the SCADA for distribution stations project.

The intent of the Specification is to describe KPLC's needs for the new RTUs to be provided and to be integrated as part of the already existing SCADA/EMS system. Each bidder is encouraged to propose its standard RTUs to the extent possible, as long as it meets or exceeds the requirements of this Specification.

The Section also describes the equipment and works necessary to interface all controls to be executed and all data to be acquired from the substation control and switchgear equipment to the RTUs.

The 48V DC supply equipment for the RTUs and adaptation equipment as well as for the telecommunication equipment provided under the contract and described in other section of this document is also specified in subsequent chapters.

#### 2.1.3.1 General information and scope

- *Site Survey*

A site survey to each site shall be conducted by the Contractor's personnel together with the Employers Engineers at the beginning of the project to:

- Prepare, respectively verify and amend the single line diagrams (SLDs) attached to this specification. This shall include the primary plant identification for the equipment to be controlled and monitored;
- identify existing substation and transmission line switching procedures including substation internal inter-lockings;
- Determine the exact scope of facilities to be controlled and monitored to enable the final number of I/O modules required.

While determining the number of I/O, suitability of primary station equipment for control and monitoring shall be reviewed e.g. availability of CTs, VTs, availability of motors for isolators and earthing switches, availability of auxiliary switches in the primary equipment.

The scope of the contract does not include supply or rehabilitation of primary substation equipment e.g. PTs, CTs, respectively CBs, isolators etc. and their driving mechanisms;

- collect, copy and verify station wiring diagrams required for design of the interface works;
- determine the scope and extend of the interface works including connection points, requirements for synchro check relays and schemes, interposing relays for galvanic isolation, transducers, cabling and cable trays/trenches etc. This shall include utilization of existing marshalling cubicles and interfaces where RTUs/SASs are presently installed;
- survey existing 48 V batteries, chargers and distribution panels for suitability to feed the existing and new SCADA and communication equipment;
- determine the location of the equipment to be installed under the contract at the time of site visit, to ensure that locations for installation of new equipment are clearly identified and agreed upon by the bidders;
- Synchronize of a single RTU unit or distributed RTU within each station. Physical arrangement at the station primary, control, monitoring and protection equipment and the required cabling shall be considered.
- ***Remote terminal units***

Presently, the NCC and RCCs control and monitor the KPLC Network via 123 RTUs/SAS.

In this project, new RTUs shall be supplied by the Contractor and installed at various substations within the KPLC Network.

For other stations with existing SCADA, it shall be required that data points that are not monitored shall be installed and bidders may use spare capacity of existing RTUs/SAS in the station.

The stations to be equipped with RTUs and the RTU sizing is as detailed in the scope of supply, Summary of Stations with existing SCADA equipment in the station. The bidders shall determine the expansion needed to ensure monitoring of all data in the selected stations. The contractor may use the available spare capacity of the existing SCADA equipment in the station as long as the specified minimum spare capacity is maintained. Where existing RTU is to be reused, it shall be the responsibility of the contractor to ascertain the actual status of the RTU and if need be adapt it accordingly to meet the signals requirements

**Table 2-5** below is a List of stations with existing RTU which may be re-used and/ expanded to accommodate additional station data

**Table 2-5:** Existing RTUs in the scope

<b>Region</b>	<b>Station</b>	<b>Data Acquisition protocol</b>	<b>RTU Type</b>
<b>NAIROBI</b>	Industrial 66/11kV	Direct process interface	RTU 560 – ABB
	Kikuyu 66/11kV	Direct process interface	RTU 560 – ABB
	Nairobi West 66/11kV	Direct process interface	RTU 560 – ABB
	EPZ 66/33, 66/11kV	Direct process interface	RTU 560 – ABB
	Limuru 66/11kV	IEC 61850	Sicam SAS- Siemens
<b>COAST</b>	Mbaraki 33/11kV	Direct process interface	RTU 560 – ABB
<b>WEST KENYA</b>	Kisumu 132/33kV	Direct process interface	RTU 560 – ABB
	Turkwel 11/220kV	Direct process interface	RTU 560 – ABB

**Attachment 1:**

SCADA System Alarms show details about the controls to be executed and the status indications measurements, alarms and metered values to be acquired from each individual substation.

An overview of the required RTUs as well as the communication linking to SCADA Systems can be taken out of **Table 1-1** under the details of the scope of supply.

Each individual RTU to be supplied under the Contract shall be fully equipped for the actual amount of data to be acquired and commands to be executed plus a spare capacity of 25% for each type of data. The 25% installed spare capacity for the new RTUs to be provided under the Contract is included in the data count given in **Table 1-1** in the scope of supply.

In addition, each RTU shall be expandable in the field by at least 50% of the size of the initial point capacity of **Table 1-1** by addition of Input and Output cards only. The addition of enclosures, internal cabling/wiring, chassis, or power supplies shall not be necessary when adding these I/O cards.

The Supervisory Control & Data Acquisition (SCADA) System at the NCC and RCC’s shall be able to scan the RTUs utilizing the communication network described in chapter 3 of this document.

The Contractor shall be responsible for the complete design, installation, wiring, testing, commissioning and documentation of the new RTUs, as well as all the works and tasks needed by the reinstallation/expansion of the existing RTUs, including any required new or parallel connections to KPLC's field equipment as described in this Specification.

- ***Data acquisition principles***

At all substations where new RTUs are to be installed and existing RTUs are to be expanded and/or spare capacity 38ynchron, interfacing of the supervisory controls to be executed and data to be acquired under the project, described above in Chapter 1.2.1 above, under “Teleinformation plan”, shall be provided.

- ***Interfacing works***

The Contractor shall supply and install all necessary equipment and material including transducers, auxiliary relays, interposing relays, cables, wiring, terminal blocks, test switches, isolation devices, conduits, cable trays/trenches and any other equipment required to interface the RTUs with the substation equipment.

The data points shown in **Attachment 1**(site survey reports) of this specification are wired up to the existing RTUs either directly from the station control and monitoring equipment or via interface marshalling cubicles depending on the amount of signals.

The field instrumentation, devices and connections shall not affect the current operation of the existing substation equipment.

The Contractor shall be responsible to perform any modification to substation facilities to accommodate the RTU equipment, power supply and other associated equipment as well as to accommodate the communication equipment supplied and installed under the Contract.

If in some substations with RTU equipment, the existing DC supply system is not in acceptable conditions, the Contractor shall supply and install in those stations new 48 volts DC batteries, chargers and associated distribution equipment required to supply the RTU as well as the communications equipment supplied and installed under the Contract.

All the data points indicated in the Teleinformation plan, which are not yet connected to the existing RTUs, have to be wired up to the new and/or existing RTUs.

The points of interfacing of controls, status indications, measurements and metering at the substations are mainly the control panels or control desks located at the power station or substation control and rooms.

At most stations, the origin for acquisition of alarms are the protection panels installed at the station control rooms or at separate protection rooms.

At all stations, tap changer position indications of OLTC – Interbus transformers are available at the control panels at the station control rooms.

For measuring of active/reactive power the interface point for acquisition is the control and protection compartment at the respective cubicles installed at a different room within the station control building or at the respective outdoor switchyard.

During the design stage of the interface works, the Contractor shall calculate the additional and the total burden for all CT secondary for all feeders where new transducers are to be installed under the Contract.

The new equipment shall be adapted to site conditions as:

- Station voltage: 30 V DC, 110 V DC, 220 V DC or 240 V AC
- CT's – secondary: 1 A or 5 A
- VT's – secondary:  $110/\sqrt{3}$  V or 110/3 V or 100/3 V

### **2.1.3.2 Functional requirements for new RTUs**

- ***Remote terminal units***

The new RTUs shall be programmable, with real time clock, synchronized by an external source, process Input and Output (I/O) modules, CPU, memory and data transmission equipment. The new RTUs to be supplied and installed under the project shall provide at least the following functions:

- single command outputs, double command outputs
- regulation command outputs e.g. raise/lower command outputs for transformer tap changer control
- analog setpoint transmission and output

- single, double and multiple state digital inputs
- analogue measured inputs
- metering pulse inputs for acquisition of energy meter values
- Sequential Event Recording (SER) with time stamping of events at the RTU
- RTU time synchronization
- Self testing and diagnostic functions for detection and reporting of any error
- automatic re-starting function
- Database and parameter setting by menu-controlled dialogues from a local PC and remotely from the corresponding control centre with downloading function.
- Support encryption and LAN/WAN access
- Shall support IEC 61850 protocol for process communication

Bidders shall with their offer inform about the different types of data transmission protocols available and for the proposed type of RTU.

- Telecontrols

The RTU shall have the capability for the SCADA system master station to select and control specified power system devices. The following power system devices will be controlled by the RTU:

- two-state devices such as circuit breakers and isolators
- multi-state devices such as transformer tap changers

### **Telecommands**

The RTU shall ensure that only the correct output is selected for two state devices before command execution.

Operation of control outputs shall be via a select-check-execute command sequence. The control sequence shall include the following:

- The SCADA system shall transmit a command message addressing the proper RTU and the control point within the RTU, and indicate the control action desired.

- The RTU shall initialize its control logic, reassemble the command message, and transmit the reassembled message to the SCADA system. The message sent to the SCADA system shall be generated by the RTU's point selection logic.
- The SCADA system shall check the returned message for validity and, if valid, shall issue an execute command to the RTU.
- The RTU shall operate the control point selected only after the execute command has been received.

The control action shall be executed only if the select-check-execute sequence is performed without error or interruption. The RTU shall reset its control logic upon any error in the sequence or if the execute command is not received within a pre-defined time after the command message is received at the RTU.

The impedance of the output circuit shall be measured to detect jammed contacts.

The point selection logic for the control output shall be designed to preclude operation of an unselected output under single component failure conditions. That is, no single component shall be capable of selecting and operating an output point by itself.

In no case, any unwanted telecommand shall be given to the process in case of an RTU power failure.

The RTU communications protocol shall also support "immediate execute" contact outputs (where an operation can be commanded without the validity check and execute message exchange) for control output types such as On Load Tap Changer (OLTC) raise / lower command outputs.

### **Analog setpoint control**

The RTU shall provide for analog setpoint control and variable pulse width outputs although this type of control as it would be required for LFC.

- Teleindications

Teleindication refers to status information of operational equipment monitored by the system. Such teleindications include status information of switching devices, event information, alarms, etc.



The RTU shall report teleindications by exception but shall also allow the SCADA system to demand – scan status data even if the data has not changed.

### **Status indications**

The status (open / closed) of two state devices such as circuit breakers or isolators shall be acquired by 2 independent, potential – free contacts or by 2 interposing relays, one for each position. Position indications shall be checked for validity and undefined states like open **and** closed (1 | 1) or **neither** open **nor** closed (0 | 0) shall be alarmed. The RTU shall provide for run-time-monitoring, adjustable to the HV equipment operation parameters, to avoid alarming of undefined states while the equipment (e.g. isolator) is operating.

### **Alarms**

Alarms shall be acquired as single indications via potential – free contacts which are either available at the initiating equipment or to be generated by paralleling relays to be provided under the project.

### **Digital parallel input**

The RTUs shall have the ability to handle digital measurands, e.g. four digits BCD. Transformer tap position shall be coded by means of a diode matrix to a BCD code before connecting to the digital parallel inputs of the RTU. The Tender shall include complete functional and electrical specifications of possible input codes and input circuits in the tendered system.

- **Telemeasurements**

Analogue measurements can be acquired from either an analogue input board supplied by the output of an analog transducer, a transducerless measurement board or a communication network. The analog signals shall be converted to digital mode by an analog-to-digital converter, to which the inputs are connected. All inputs of a module shall be measured within one cycle, regardless of the number of inputs in use. Thus new points can be added to the RTU without reprogramming.

Analog measurements shall be transmitted to the master station with 12 bits or 11 bits + sign bit.

- **Telemetry**

The transmission of integrated totals refers to the transmission of measurable quantities which are integrated over a specified period of time. The integration shall take place before transmission.

The measured quantity such as active or re-active energy (kWh, kVarh), which is presented as defined pulses which are read into an integrating register of the RTU from a pulse output or a closing contact of an energy meter.

Transfers of the accumulated counts into a storage area shall be initiated every 1 minute by the RTU clock. In case of a failure to scan, e.g. due to failure of the telecommunication system, 1-minutes integrated totals over a period of not less than 1 day shall be stored at the RTU

Pulse accumulator data shall be assigned to a scan group for scanning of the accumulated values from the SCADA system.

- **Sequence of Event Recording (SER)**

The RTU shall be capable of Sequence-of-Events (SER) data collection at a time resolution less than the operating speeds of the power system devices. Any digital input points in the RTU may be assigned, programmable as an SER data point. In general, a breaker position change and any alarm from a protection device that has initiated a trip signal is defined as an event for SER. Multiple transitions of a device, such as the tripping and subsequent reclosing of a breaker, shall be considered as a series of separate events. Each time an event is detected, the RTU shall time-tag the event and store it together with the time-tag of the event for transmission to the SCADA system with the next scan.

The buffer shall be sized to store, as a minimum, a number of events equal to three times the number of SER points implemented in the RTU.

The time-tag recorded with each event shall be generated from a clock internal to the RTU.

### **Separating capability**

The RTU shall be capable of correctly determining the sequence of events for which their occurrence is separated by  $\geq 1$  ms (separating capability class SP4 of IEC 60870-4)

### **Time resolution**

The resolution of the time tag shall be 10 ms.

- Common time base

The internal clock of each RTU shall be synchronized either from, a Contractor supplied and installed time synchronization source, such as a Global Positioning System (GPS) or an omega synchronizing signal.

The synchronization shall be done periodically such that the time-tags in each RTU shall be within five milliseconds (5 ms) accuracy between all RTUs.

Tenderers shall clearly indicate the method used for time synchronization and describe in detail how the required accuracy is achieved.

In the RTU there shall be a digital output from which time synchronization messages can be forwarded to external devices. The frequency of the activation of the message shall be adjustable.

- Data transmission

The data transmission network will consist of dedicated data channels and/or TCP/IP network utilizing fibre optic transmission media, power line carrier and radio transmission.

The RTU shall be capable of providing both legacy and cutting edge communication interfaces.

The new RTUs shall be capable of “dual port function”, utilizing different protocols on at minimum 2 separate RTU communication ports simultaneously. Communication protocols shall be implemented by modifiable firmware in the RTU. Reconfiguration of the RTU database may be necessary when an RTU’s communications protocol is changed due to the difference in the functions supported by the protocol.

The Contractor shall provide and implement RTUs with standard IEC 60870-5-101 communications protocol as well as IEC 60870-5-104 communications protocol. Both protocols shall be included and shall be selectable for each of the RTUs by parameterization. The interfaces to the different communication media for IEC 60870-5-101 and IEC 60870-5-104 shall be provided by the RTU hardware.

The RTU protocol shall be non-proprietary for use within KPLC. The Contractor shall provide all details and parameter settings used under the IEC 60870-5-101 and IEC 60870-5-104 protocols. KPLC shall be authorized to disclose the RTU protocol to third party suppliers.

### ***1.1.1.1 Functional requirements for adaptation works***

This Section is dealing with the interfacing equipment and works to be performed at the substations.

- Analogue and digital input data to RTU

Power system analogue and digital input data shall be collected from the substation field instrumentation and provided to the RTUs. Interfacing shall be designed to minimize electromagnetic and electrostatic interference. Galvanic isolation shall be provided for all inputs and interposing relays shall be used.

#### **Analogue measurements**

The interfacing shall consist of analogue transducers, isolating/test devices, wiring, cabling and terminations to the secondary PT/CT circuit in the control or relay cabinets. The output signal from the analogue transducer shall be transmitted to the appropriate input at the RTU. This refers i.e. to MW/MVAr, Current and Voltage measurements.

#### **Status indications**

The interfacing shall use spare potential free contacts where available or auxiliary paralleling relays to be provided under the Contract, (one independent contact / relay for each position) actuated by the switchgear equipment, isolating and test devices, wiring, galvanic isolation, cabling and terminations to the digital input point at the RTU.

#### **Alarms**

Input wiring to the RTU from alarm points shall use spare contacts available on the actuating device wherever possible. Where spare contacts are unavailable, auxiliary “contact multiplying” relays shall be supplied and wired to provide the required digital input signal to the RTU with galvanic isolation.

#### **Pulse accumulation**

The pulse accumulation interfacing shall utilize potential-free pulse contacts or pulse outputs of electronic meters if available, isolation and test devices, wiring, cabling and terminations to the RTU. Where potential free pulse contacts or pulse outputs are not available, new meters shall be provided under the Contract.

- Supervisory control interface

The substation adaptation works for device control will be required to take an output signal from the RTU, actuate an auxiliary control relay, and have a contact from the control relay to initiate a control action such as breaker trip/close, etc. on the substation equipment by the appropriate connections to the substations equipment control circuits.

The supervisory control interface shall consist of outputs from the RTU, interposing relays, isolating/test devices, and wiring, cabling and terminations to the appropriate control circuits and control relays and switches in control cabinets.

Each RTU control output shall drive an auxiliary control relay, which shall be located in the control panel or locally. The interposing relay shall be normally de-energized during normal operation. A normally open contact of these interposing control relays shall actuate a breaker tripping/closing coil. In no cases shall the relay contacts supplied in the RTU directly control any equipment.

The circuit breaker close command in stations where separated networks / generation could be switched shall pass through synchro-check relays to prevent CB closing under none-synchronous conditions. Installation of synchrocheck relays under this contract is part of the project tasks under the Contractors responsibility.

In no case shall the closing commands for circuit breakers by-pass any station internal interlocking.

For OLTC devices, appropriate latching relays shall be utilized.

A key type selector switch shall be installed for each feeder equipped for remote control from the corresponding Control centre. The switch shall allow selection of control from the Control centre or from the substation and its position shall be indicated at the corresponding Control centre.

The Contractor shall provide and install suitable test switches or isolating devices for all control points, to allow for proper control isolation, testing, safety procedures.

### **2.1.3.3 Equipment characteristics**

#### ***Remote terminal units hardware***

- Enclosures

The Contractor shall provide enclosures meeting the following requirements:

- Swing racks supported by heavy gauge hinges shall be provided so that only front access to components and wiring is required for routine maintenance and troubleshooting.
- Provisions for top and bottom cable entry. Cable entries shall be provided with protection against insect and animal entry, and sealed to prevent dust and sand contamination.
- Protection class of the enclosures shall be
  - for indoor cabinets IP52 minimum
  - for outdoor cabinets IP64 minimum.
- Suitable signal and safety ground networks within the enclosure.
- Convenience outlets at 230 V AC, shall be provided.
- Power supply

The Contractor shall supply any hardware required to convert the 48 V battery voltage to the required internal voltages for the RTU hardware. The RTUs shall be capable of operating with ungrounded or grounded (either polarity) input power.

In RTU DC distribution, Miniature Circuit Breakers (MCBS) with alarm contact shall be used, i.e. fuses are not accepted.

- Control disable switch

For each station a manual key type selector switch shall be provided to locally disable all control outputs at a station. The key-type selector switch shall be installed at the RTU such that it can be operated without opening the RTU panel. The outputs from the RTU shall be disabled by breaking the power supply connection to the control output. An auxiliary contact on this switch shall be wired to a contact input in the RTU to report the control disable switch's status to the SCADA system.

- Interconnections

All connections between the RTU's termination facilities and signal wiring shall be through barrier-terminal blocks with knife-switch isolation, mounted in the RTU panel or an adjacent marshalling cabinet, if not already exist in the Substation. Terminal blocks shall be screw-type,

with full depth insulating barriers. There shall be galvanic isolation of all signal wiring via interposing relays

- Distributed RTUs

RTUs shall have the capability to gather data from other smaller or distributed RTUs or local intelligent substation instrumentation using standard RJ45 Ethernet , or directly connected RS-232C- or RS 485- channels with or without modems. The distance between the different control locations may reach up to 500 m.

- Digital inputs

The digital inputs shall be opto-isolated, signal voltage 48 V DC. Other voltages shall also be possible by changing the matching resistor in the input circuit.

Contact bouncing of the interposing relays shall be filtered. The bounce filtering time shall be 7ms. Input circuits with selectable bounce filtering time setting are preferred.

The indications shall preserve the chronological order of events inside the RTU.

Oscillating inputs as a result of e.g. a faulty relay chattering shall be blocked locally at the RTU.

- Analogue inputs

In analogue measurements, the information to the analog input modules of the RTU is given in the form of analog current supplied by the output of measuring transducers. Measuring transducers shall normally be installed in the switch/control gear.

In analog input modules, the following current input ranges shall be available:

- unipolar 0-5 mA, 0-10 mA, 4-20 mA, 0-20mA
- bipolar +/- 5 mA, +/-10 mA,+/-20mA

It shall be possible to change the input range for each individual input, preferably by software means, instead of changing the input resistor.

The analog input circuit shall have a precise DC impedance less than 200 ohms for current inputs. This impedance must not vary more than half of the accuracy of the Analog to Digital Converter (ADC) with influence values such as temperature, etc.

In the input circuit galvanic isolation shall be provided from mechanical earth and electrical earth, and, preferably, between different inputs.

The circuits of the analog input module shall be protected against disturbances caused by switching transients and against disturbances from power and radio frequencies present at outstations.

The scanning of each input shall not introduce any error on the analog information.

For each input it must be possible, without disturbing the other inputs,

- to isolate the input from the ADC and close the analog circuit,
- to connect, on the ADC side, a test set for maintenance or adjustments,
- to measure the analog input value without disturbing the measurement (addition of an mA meter over a link which is then disconnected).

The analog information shall be converted into digital value by the ADC which can be common for all inputs. Analog measurements shall be transmitted to the master station with at least 11 bits plus sign bit.

The total accuracy must be better than 0.5% of the nominal range of a measurement calculated from RTU's analog input up to Control Centre. A calculation of the total accuracy in the wide sense as well as in the restricted sense as per IEC 870 – 4 shall be included in the Tender.

The input circuits must withstand a permanent overload of 30% without any damage.

In case of input overload the output message shall be either

- the exact value corresponding to the input or
- the maximum value that is possible to code (with the correct sign).
- Pulse inputs

The counter register shall be 16 bit. The maximum input frequency shall be 25 Hz. In practice, the pulses will be dimensioned in a way that max. frequency is less than 5 Hz. Interposing relays will not be used.

- ***RTU firmware requirements***

The RTUs shall meet the following characteristics of the firmware to support the functions of the RTUs. The Contractor shall use standard firmware as much as possible.



All firmware shall be completely and consistently documented. It shall not be necessary to perform modification to firmware, logic, or data for expansion within the sizing parameters defined for the RTU.

At the time the RTU is accepted, all firmware delivered must be up to date and in final form, including all standard firmware changes and field changes initiated by the Contractor or the Contractor's suppliers prior to acceptance. The firmware documentation must reflect these changes.

Firmware shall be loadable by service notebook locally at minimum, download of firmware and parameter sets through SCADA system, using the data communication links will be preferable. In any case changing of EPROMs or similar devices shall not be necessary when updating RTUs firmware.

- Initialization / restart program

Firmware shall be provided to enable the RTU to restart itself upon manual request and automatically under the conditions of power restoration, memory parity errors, and hardware failures. The firmware shall initialize the RTU and begin execution of the RTU functions without intervention by the SCADA system. All RTU restarts shall be reported to the SCADA system.

- Fail safe processing

In the case of irrecoverable faults such as power supply failures, firmware malfunctions, or any other detected condition that may affect the security of indications and controls, the RTU shall place itself in a secure state that prohibits the transmission of false indications or the execution of erroneous control outputs. The detection of these error conditions shall be the responsibility of the RTUs self-test and operations monitoring firmware.

- Database maintenance

The Contractor shall supply software to configure each RTU's database where this information is located in software and/or firmware at the RTU. The software shall completely generate or modify the database of the RTUs. The database software shall have error detection services and shall produce a printed listing of the input data and the resulting RTU database configuration.

- Down loading of database from SCADA system

The RTU shall support the change of the RTU's configuration and processing parameters by messages from the SCADA system. These changes shall include, but not be limited to scan group definitions, analog limits, SER point allocation and buffer definitions.

- Diagnostic firmware

The Contractor shall supply diagnostic firmware for both off-line local tests and on-line self-diagnostic capability built into the RTU. The RTU shall enter an off-line state during the execution of off-line diagnostics, and this off-line state shall be reported to the SCADA system.

The RTU shall include a remote diagnostics communication port and shall be capable of executing off-line diagnostics from an external computer terminal connected to this remote diagnostics port.

### ***Interfacing equipment***

- Interposing relays

Interposing relays for telecommands and digital inputs shall be provided by the Contractor. The relays shall be installed in the switch / control gear and shall have the following characteristics:

For telecommands:

- Coil voltage shall be 48 VDC; Coil voltage variation shall be +/-20%.
- Signal voltage on the contact circuit shall normally be 110 VDC, but other voltages may also exist.
- The rated contact current shall be minimum 5 ADC making/breaking. In exceptional cases, where CB coils are to be switched directly by the interposing relay, installed under the contract, additional contactors might be required to cope with the switching currents of the CB coils. In such cases, these contactors shall be provided under the contract.

For teleindications:

- Coil voltage shall normally be 110 VDC; (other voltages may also exist) coil voltage variation shall be  $\pm 20\%$ .
- Signal voltage on the contact circuit shall be 48 VDC.

- The rated contact current shall be minimum 3 A DC making/breaking and 1 A continuously

Relays with two (2) normally open and two (2) normally closed contacts shall be provided. Contact bounce shall be less than 8 ms and contact age shall be 10 exp. 6 operations.

Dielectric strength shall be 2 kV, 50 Hz-1 min between one circuit and the earthing point and between independent circuits, 1 kV, 50 Hz for 1 min between two terminals of the same circuit, Impulse test voltage: 5 kV (IEC 60255-5).

Plug-in type relays and sockets shall be used with sockets directly mounted on a DIN rail.

All necessary arrangements must be made so that the plugging – in and out are easy and performed without any risk of damaging of relay parts.

The relays shall be fitted with a visual operation indicator (either mechanical or LED).

### ***Transducers***

The new transducers shall be of the latest state-of- the art solid state technology, not requiring frequent calibration and preventive maintenance and shall be free from electro-magnetic interference and noise. They shall use electronic surface components and all its internal parts are protected by a tropicalization varnish. Transducers shall comply with the latest international standards and, mandatory, to the IEC 60688-1 publication.

Transducers shall be programmable and the respective programming equipment/software shall be provided in this contract.

Transducers shall in general be installed in the control or protection board of the switchgear equipment. Transducers shall preferably be plugged into a safety socket and shall be easily removable and replaceable during operation. If the transducer uses current circuits, these circuits are automatically shorted when extracting the transducer from its socket.

Transducers shall comply with the following requirements:

- Accuracy of the measurements for MW, MVA<sub>r</sub>, voltages shall be better than 0,5% of full scale over a temperature of 0 to 50 °C.
- Maximum ripple shall not exceed 2% peak to peak.
- Response time to 99% of final value shall not exceed 0.5 sec.
- The analogue output of the transducers inputs to the RTU shall be isolated, unipolar or bipolar, 2 – wire Load independent DC current of 0 to 10 mA, or ±10 mA or 4-20mA.
- Transducer burdens shall not exceed 2 VA per PT element and 2 VA per CT element. The contractor shall provide calculations of the additional burden imposed by the transducer and the associated wiring / cabling for each transducer installed under the project during the detailed design stage of the project.
- Transducers shall be able to withstand a short period (1 second) overload of up to 50 A without damage and have a withstand voltage of 4 kV/50 Hz/ 1 min and 5 kV/1.2/50 μs, according to IEC 60255-4 C1. III.

Frequency transducer shall have an input range from 45 Hz to 55 Hz.

Active and re-active power measurements shall be made 3 phase – 3 wire for distribution indoor switchgear circuits and 3 phase – 4 wire for other circuits.

A single phase-to-phase voltage shall be acquired for each measurement point. Voltage transducer shall provide for expanded scale of +- 20% of the rated voltage.

OLTC transformer tap positions are available either in analogue form or from drum switches with individual switches for each tap position (e.g. one out of 19).

Transformer tap position from the drum switches shall be coded by means of a diode matrix to two digit BCD code before connecting to the digital parallel inputs of RTU.

For transformer tap position available in analogue form, analogue transducers shall be provided. These transducers shall convert the current tap position of the TC to a suitable sealed analogue input to the RTU.

### ***Cables***

The instrumentation cables from the RTU electronics cabinet to the interface terminals at the substation control / switchgear shall be delivered by the Contractor.

The characteristics of the cables shall be as follows:

- Number of cores  $n * (2+1) * 0,8 = 2, 4, 8, 12, 24, 48$ , with  $2 + 1 =$  a pair of conductors + surrounding screen and  $0.8 =$  cross-sectional area of screen.
- The outer PVC sheath shall be rodent proof and meet flame test requirements of IEC 60323-3 category C. Manufacturer's name, manufacturer's type, core quantity and cross-section, year and month of manufacturing shall be indicated.
- Individual leads shall have colour coding.
- Pair-twisted cores, each pair and the whole core surrounded by protective screen shall be used for connection of transducer secondaries to the RTUs. For connection of controls, status indications and alarms cables with protective screen surrounding the whole core are acceptable.

In the design made by the Contractor the following shall be taken into account:

- Separate cables shall be used for:
  - telecommands,
  - teleindications and alarms
  - measurements transducer secondary outputs (mA)
  - metering (kWh)
- The number of cables should be as low as possible.

#### **2.1.3.4 Power supply for substations**

At all stations where no adequate power supply exists and new RTUs and telecommunication equipment shall be installed, the Contractor shall supply, install and wire a new and complete 48V DC power supply system including a 48V DC battery, charger(s), low voltage disconnect switch, all DC distribution equipment and cabling required for the uninterruptable supply of 48V DC power to the RTU as well as the communications equipment provided under the Contract.

The battery and charger sets shall be sized to adequately supply the loads to be connected to the battery. The rectifier output shall be  $k \times S$  where

$k = 1.5$

S = sum of the following:

- input power in kVA of the largest tendered RTU
- input power to the new telecommunication equipment provided under the contract.

The battery capacity shall be  $C = 1.5 \times C_n$ , where  $C_n$  is the capacity to feed the above total load for eight (8) hours.

The battery chargers shall provide normal system power and shall be capable of recharging a fully discharged battery in twelve hours while supplying normal system power. The chargers shall have 240 volt, 1 phase input power. Where duplicated chargers are to be provided, both chargers shall have an output diode in the positive pole to prevent back-feeding a failed charger.

The batteries shall be sealed, maintenance free lead acid type. As they are sealed, there are no special ventilation requirements, and as such the batteries may even be placed in the substation control rooms or communications equipment rooms.

A low voltage disconnect switch shall be provided for protection of the battery. The 48 Volt DC system distribution panel shall be a fused switch distribution panel board. The low voltage disconnect switch and fuse panel shall be provided with local alarms as well as alarm contacts. The low voltage disconnect switch shall be equipped with external by-pass switch to be used for maintenance purposes.

#### **2.1.3.5 Spare parts and test equipment**

- *Spare parts*

The Contractor shall furnish a list of recommended spare parts and test equipment for the purchased RTUs to maintain reliable RTU operation. The spare parts list shall be subdivided into:

- short-term spare parts that are necessary for two (2) years of operation. These spare parts shall be included in the contract.

- long-term spare parts that are necessary for ten (10) years of operation.

The Contractor shall guarantee the availability of spare parts for a period of at least 15 years and shall make available at no cost to KPLC the manufacturing drawings and rights to manufacture those subassemblies which the manufacturer will not support, or discontinues support thereafter. For each subassembly, the specific components supplied shall be identified and referenced in the supplied documentation.

- ***Portable test set***

The Contractor shall supply 2 portable RTU test sets (notebooks) for testing RTU operation. Each test set shall be capable of emulating communications from both the SCADA system and the RTU. The test sets shall have the capability of interfacing to an RS232C serial port for the RTUs being supplied on the project. Test sets shall be capable of passively monitoring all communication traffic on a channel without interfering with channel operation.

In addition each test set shall include interface testing equipment for simulation of digital and analogue inputs, digital and analogue outputs.

- ***Ferrule Marking Machine***

The contractor shall supply 2 no. ferruling machines. These shall be used for maintenance works in the substations.

The ferrule marking machine shall have the following specifications;

**Technical Description/Specification**

- Ferrule Printing Machine High-speed marking Marking speed at 35mm/second. Mark 50pcs of 20mm-lengthtube per min.
- Maximum printing length Tube : 20M Tape : 5M
- Maximum 100,000 character internal memory storage
- Easy access to your PC with application software
- Can import text and setting data from PC with USB 2.0 Interface for faster & big-volume markings.
- Marking method Thermal transfer method(300dpi)
- Display LCD dot matrix : 64 x 160 Pixel (Backlit)

- Marking speed 35mm/s(Standard) 20mm/s(Low temperature mode)
- Maximum No. of characters to input 5,000 characters
- Character size 2,3,4,6mm height (PVC, Shrinkable tube)
- Ferrule Printing Machine Usable tape size Width 5,9,12mm
- Tube cutting method Auto half cut, manual full cut
- Ferrule Printing Machine Internal memory 100,000 characters (50 files)
- Ferrule Printing Machine External memory: USB Memory
- Power supply DC 12V, 3.3A Use only specified AC adapter (100V-240V) appended to machine.
- Power consumption 16W (max.)
- Operating environment 10 to 35 degrees Celsius

#### **2.1.3.6 RTU performance requirements**

- ***Availability***

An availability of 99.9% is required exclusive of communication channel availability. An RTU shall be considered unavailable when:

- any function is lost for all points of a single type
- one input card or output card of each type fails
- More than one input card or output card of the same type fails.

- ***Maintainability***

The RTU design shall facilitate isolation and correction of all failures. The following features which promote rapid problem isolation and replacement of failed components shall be included:

- self-diagnostic capabilities continuously monitoring operation of the RTU
- on-line error detection capabilities including detection of memory, CPU, communication faults, and input/output errors and failures with detailed reporting of detected errors to the SCADA system
- Local indication of RTU failures.
- ***Message security***



Each message transmitted shall include an error detection code to exclude erroneous messages being accepted as valid.

#### 2.1.4 Guaranteed Technical Particulars

**Table 2-4 Guaranteed Technical Particulars**

	<i>SCADA EQUIPMENT FOR SUBSTATIONS</i>		
	<i>Tender Schedules</i>	<i>Unit</i>	<i>Tendered Data</i>
<b>1.</b>	<b><i>Remote Terminal Units</i></b>		
	Manufacturer		
	Type		
	Dual Port Capability		
	Supported communication protocols		
	IEC 60870-5-101 on both channels		
	IEC 60870-5-104 on both channels		
	Transmission speed channel 1	Bit/s	
	Transmission speed channel 2	Bit/s	
	Remote Terminal Capacity:		
	Total number of analog inputs		
	Total number of status inputs (one/switch)		
	Total number of status with memory inputs		
	Total number of alarm inputs		
	Total number of MWH and MVARH accumulator inputs		
	Total number of control outputs		
	Total number of analogue outputs		
	Transmission time:		
	single-point commands	Sec	
	single-state indications	Sec	
	measured value correction	Sec	
	Data Priority facilities		

	Permissible signal distortion for safe operation	%	
	Accuracy of the entire measuring loop		
	metering transducers	Max. %	
	transmission equipment	Max. %	
	Measured value-input	mA	
	output	mA	
	at 1 Ohm		
	load impedance		
	digital output		
	Power supply voltage	V DC	
	Power consumption fully equipped	W	
	Mode of operation		
	commands		
	indications		
	measured values		
	Pulse train code		
	address-bloc		
	information-block, indications		
	measured values		
	commands		
	metering readings		
	check bits		
	Hamming Distance		
	Dimension of RTU cabinets and Marshalling Cubicle (packs) completely equipped and wired		
	height	cm	
	width	cm	
	depth	cm	
	Protection class for cubicles (IP 52 min.)		

<b>2.</b>	<b><i>Voltage transducer</i></b>		
	Manufacturer		
	Type		
	Accuracy (at ambient temp. 0 – 50°C)	%	
	Ripple (peak to peak)	%	
	Response time to 99 % of final value	sec.	
	Input voltage	V	
	Output current	mA DC.	
	Auxiliary voltage	V DC.	
	Test voltage (input to earth)	kV	
	Power consumption	VA	
	Module dimension	cm x cm	
<b>3.</b>	<b><i>Transducer for active / reactive power</i></b>		
	Manufacturer		
	Type		
	Accuracy (at ambient temp. 0 – 50°C)	%	
	Ripple (peak to peak)	%	
	Response time to 99% of final value	sec	
	Frequency	Hz	
	Input		
	current	A	
	voltage	V	
	Output current	mA DC.	
	Test voltage (input to earth)	kV	
	Power consumption	VA	
	Auxiliary voltage	V	
	Module dimension	cm x cm	

<b>4.</b>	<b><i>Current transducer</i></b>		
	Manufacturer		
	Type		
	Accuracy (at ambient temp. 0 – 50°C)	%	
	Ripple (peak to peak)	%	
	Response time to 99 % of final value	sec.	
	Output current	mA DC.	
	Auxiliary voltage	V DC.	
	Test voltage (input to earth)	kV	
	Power consumption	VA	
	Module dimension	cm x cm	
	Module dimension	cm x cm	
	Ripple (peak to peak)	%	
	Response time to 99 % of final value	sec.	
	Input voltage	V	
	Output current	mA DC	
	Auxiliary voltage	V D.C.	
	Test voltage (input to earth)	kV	
	Power consumption	VA	
	Module dimension	cm x cm	
<b>5.</b>	<b><i>Frequency transducer</i></b>		
	Manufacturer		
	Type		
	Accuracy (at ambient temp. 0 – 50°C)	%	
	Ripple (peak to peak)	%	
	Response time to 99 % of final value	sec.	
	Input voltage	V	
	Output current	mA DC	

	Auxiliary voltage	V D.C.	
	Test voltage (input to earth)	kV	
	Power consumption	VA	
	Module dimension	cm x cm	
6.	<b><i>Interposing relays for supervisory control</i></b>		
	Manufacturer		
	Type		
	Operating voltage		
	coil	V D.C.	
	contacts	V D.C.	
	Test voltage	kV	
	Number of N.O. contacts		
	Switching cycles lifetime (mech.)		
7.	<b><i>Interposing relays for status indication</i></b>		
	Manufacturer		
	Type		
	Operating voltage		
	coil	V D.C.	
	contacts	V D.C.	
	• Test voltage	kV	
	• Number of N.O. contacts		
	• Switching cycles lifetime (mech.)		
8.	<b><i>Ferrule Marking Machine</i></b>		
	Manufacturer		
	Type		
	Operating voltage		
	Weight		
	Dimensions		

## **2.2 Integration of the new stations to the SCADA/EMS system**

### **2.2.1 General Information**

Data Engineering Tool (DE400) is the application software package used for off-line data entry of the Network Manager SCADA/EMS/DMS system. The tool is used for both the initial process data entry and for the process data maintenance. The tool is commonly referred to as DE400. After all the offline data engineering is performed, DE 400 tool is used for either incremental or total population of the real-time Network Manager Avanti Database population

### **2.2.2 Data Population**

It shall be in the scope of the contractor to generate the individual station displays and populate the KPLC' Network Manager system database with all the station data, for full SCADA operability. All the data engineering work shall be done in close consultation with the KPLC SCADA/EMS experts.

The complete database population shall be handled by a professional who fully understands and is well experienced in the functions of the Data Engineering tool (DE 400) and the Network Manager SCADA/EMS system as a whole.

Tests shall be required to ensure the data-flow from the RTUs up to display presentation and vice versa.

There are available workstation equipment that serve as maintenance and training/operator console at the NCC and all other control centres. These workstations also have the data engineering software which the contractor's expert may use for the required database population and station displays and reports

### **2.2.3 RTU and SCADA tests**

#### **2.2.3.1 Factory Acceptance Tests**

The RTUS shall pass agreed set out tests before they may be shipped to site. KPLC shall witness FATs unless he waives this in writing. FAT preparation costs shall be borne by contractor except transport and accommodation, which shall ne catered for by KPLC. FAT shall be carried by two KPLC staff for 5 days.

#### **2.2.3.2 Site acceptance Tests**

The RTUs shall pass agreed set out tests before they may be put into operation and before they are handed over to the employer. The RTUs will be accepted by KPLC if both:

The RTUs and all items of the equipment have successfully completed all the specified tests  
All failures, problems and reservations noted during the tests have been corrected to the satisfaction of KPLC.

If either of these conditions has not been complied with, then the necessary corrective action shall be agreed between the Contractor and KPLC.

#### **2.2.3.3 Commissioning Tests**

After completion of RTU interface works in the stations all type of inputs / outputs at the stations' RTUs, shall be tested from National or Regional Control Centres. The tests shall include:

- Remote control of circuit breakers, isolators and transformer tap position.
- Status indication of circuit breakers, isolators, earthing switches, transformer tap position. Indications shall be manually selectable but shall also react to remote controls as the actual devices at the substation e.g. open, close, intermediate position, different time behavior, out of tap etc.
- single digital input to confirm persistent and fleeting alarms
- adjustable analog input in the range of 0...100%
- adjustable analog input in the range of -100%...0...100%
- Energy counter to simulate energy meter readings.

## 2.3 TRAINING

1. The Contractor shall provide 2 weeks training for 2 (two) KPLC staff at the supplier's factory premises and on site during installation works and the scope of each service shall be given.

The training shall cover configuration, testing and commissioning of the RTU/gateway supplied by the contractor.

On completion of the training, KPLC staff shall be able to modify and make changes to the configuration of the supplied RTU to accommodate any future changes as well as interfacing & data transmission to the NCC/RCC.

All training costs shall be borne by Contractor except travel to manufacturers place and accommodation which shall be borne by KPLC. The scope of each service shall be given. The training content shall be subject to approval of the project Manager.

2. In addition to the basic SCADA equipment training , the contractor shall also be required to provide 2 weeks training for an 2 (two) Engineers at the supplier's factory premises or a recognized industry training institution subject to approval by the project Manager on station automation protocol IEC61850.

The training IEC61850, basic and advanced training shall include but not be limited to:

- Principles & Models (Design Principles, Information Modeling, Interoperability, Architecture: Station & Process Bus, Logical Nodes, ACSI – Class Models, DataSet, Communication models, Controls
- COMMUNICATIONS ( GOOSE / GSSE, Client / Server, Data Reporting & Logging, Sampled Values, Time Synch, GOOSE & Ethernet Frames, 7-OSI Layers & PRP/HSR, Client / Server MMS Protocol, ASN.1 Encoding & Message Parsing LANGUAGE (SCL Syntax and Semantics, .ICD/.CID Files: IED definitions.
- SCD File: Substation Section, Access Points & Communications, Engineering process: Configuration, Mandatory Software Tool
- HANDS – ON ( Create DataSets& Control Blocks, Configure GOOSE & Data Reporting, Connect to Live IEDs, Monitor & Troubleshoot Messages, Perform complex GOOSE Testing, Initiate Client/Server MMS Reporting, Message Parsing:



Apply ASN.1 BER encoding, Simulate IEC 61850 IEDs, Import SCL Files, Connect Import Setup, IEC 61850 Engineering)

## **CHAPTER THREE**

---

### **3 TELECOMMUNICATIONS**

#### **3.1 FIBER OPTIC LINKS**

The Detailed Technical Specifications for the fiber telecommunications solution shall be set out as follows;

1. The fiber optic cable specifications
2. Fiber Optic Test Equipment Specifications
3. The fiber optic terminal equipment specifications
4. The fiber optic cable & terminal equipment Spares requirement
5. Testing
6. Training

##### **3.1.1 GENERAL**

KPLC intends to integrate several existing distribution substations yet to be automated to the existing SCADA infrastructure.

This shall employ the use of various telecommunication solutions to connect these substations to their respective regional control centres for primarily SCADA connectivity and additionally for telephony and office data connectivity.

The telecommunication scope of work, fiber optic links, shall be as follows;

<b><u>DISTRIBUTION SUBSTATIONS</u></b>
--

	<b><u>Station</u></b>	<b>Link End SS</b>	<b>Approx Link Distance (kms)</b>	<b>Link Available</b>	<b>Proposed Link Equipment</b>
<b>NAIROBI REGION – STATIONS CONNECTED TO NCC</b>					
1.	Donholm 11kV	NAIROBI SOUTH	6	YES	Switches
2.	Industrial 66/11kV	NAIROBI SOUTH	8	NO	Switches
3.	Karen 66/11kV	NAIROBI WEST	14	YES	Multiplexer
4.	Limuru 66/11kV	NAIROBI NORTH	15	YES	Switches
5.	Athi River 33/11kV	EMBAKASSI	26	YES	Multiplexer
6.	Machakos 33/11kV	EMBAKASSI	61	YES	Multiplexer
7.	Nairobi Airport 66/11kV	EMBAKASSI	10	YES	Switches
8.	Nyaga 33/11kV	RUIRU SS	15	NO	Switches
9.	Muthurwa (new)	NAIROBI SOUTH	8	YES	Switches
10.	EPZ	ATHI RIVER SS	3	YES	Switches
<b>COAST REGION – STATIONS CONNECTED TO RABAI RCC</b>					
10.	Msambweni 33/ 11kV	Mwabungo 33/11kV	20	NO	Switches
11.	Mwabungo 33/11kV	GALU SS	5	NO	Switches
12.	Kanamai 33/11 kV SS	NEW BAMBURI	18	NO	Switches
13.	Watamu 33/11kV	KAKUYUNI SS	15	NO	Switches

14.	Kaloleni 33/11kV	RABAI SS	30	NO	Switches
15.	Malindi 33/11kV	KAKUYUNI SS	30	YES	Multiplexer
16.	Utange 33/ 11 kV SS	NEW BAMBURI	12	NO	Switches
17.	Shanzu 33/11kV	NEW BAMBURI	5	YES	Switches
18.	Mwatate 33/ 11 kV SS	VOI	20	NO	Switches
19.	NEW BAMBURI	RABAI SS	40	NO	Multiplexer
<b>MT KENYA REGION - STATIONS CONNECTED TO KIGANJO RCC</b>					
19.	Embu East SS	KUTUS SS	15	YES	Switches
20.	Embu 33/11kV	KUTUS SS	25	NO	Switches
21.	Karatina SS	KIGANJO 132	25	NO	Switches
22.	Kerugoya SS	KARATINA SS	20	NO	Switches
23.	Ndarugu 33/11KV	MANGU SS	10	NO	Switches
24.	Meru 33/11kV	MERU 132	8	YES	Switches
25.	Othaya 33/11kV	RURINGU SS	21	NO	Switches
26.	Githambo 33/11kV	GITHAMBO 132	21	NO	Switches
<b>WEST KENYA REGION - STATIONS CONNECTED TO LESSOS RCC</b>					
27.	Kakamega 33/11kV	MUSAGA SS	22	YES	Multiplexer
28.	Kericho 33/11kV	CHEMOSIT SS	25	YES	Multiplexer
29.	Kisian 33/11kV	KISUMU 132	14	NO	Switches

30.	Kisii 33/11kV	KISII 132	18	YES	Switches
31.	Kisumu East 33/11kV	KISUMU 132	16	NO	Switches
32.	Obote Rd 33/11kV	KISUMU 132	4	YES	Multiplexer
33.	Elburgon 33/11kV	SOILO SS	10	NO	Switches
34.	Gilgil 33/11kV	LANET SS	33	YES	Multiplexer
35.	Soilo	LANET SS	33	YES	Multiplexer
36.	Njoro 33/11 kV SS	SOILO SS	15	NO	Switches
37.	Nyahururu 33 /11 kV	RUMURUTI SS	35	NO	Switches
38.	Rongai 33/11 kV SS	SOILO SS	5	NO	Switches
39.	Mwariki 33/11 kV SS	NAKURU DEPOT	5	NO	Switches
40.	Eldoret Industrial 33/11kV	RIVATEX	8	NO	Switches
41.	Kitale 33/11kV	KITALE 132	20	NO	Switches
42.	Kapsabet 33/11kV	LESSOS	20	YES	Switches
43.	Turkwel 220 kV	LESSOS	230	NO	ETL 600 PLC Terminal Eqpt

### 3.1.2 FIBER OPTIC CABLE SPECIFICATIONS

This cable shall be installed on the distribution network below the 66kV, 33kV and 11 kV power lines.

These extensions shall originate from the existing fibre optic nodes at various locations in the power supply network in all the KPLC Regions.

For technical and administration purposes, KPLC is divided into four administrative regions namely Nairobi, Coast, Mt. Kenya and West Kenya respectively.

**The total estimated cable length to be installed in this phase is approximately 426Kms broken down into FOUR lots as per regional requirement.**

### **3.1.2.1 ENGINEERING**

**Fibre Optic Cable:** A cable that contains individual glass fibers, designed for the transmission of digital information, using light pulses

**All Dielectric Self Supporting (ADSS):** A cable that is designed for aerial applications and does not require a separate cable messenger.

**OTDR:** Optical Time Domain Reflectometer: A device used for characterizing a fiber, whenever an optical pulse is transmitted through the fiber and the resulting backscatter and reflections are measured as a function of time.

**Single Mode Fiber (SM):** An optical fiber with a small core diameter in which only a single mode of light is capable of propagation.

**Multi-mode Fiber:** An optical fiber whose core diameter is large compared with the optical wavelength and which, consequently, a larger number of light modes are capable of propagation.

**Splicing:** Making a permanent junction between optical fibers. This may be thermally fused or mechanically applied.

**Minimum Bend Radius:** The minimum radius a fiber may be bent before optical losses are induced

**ODF-** Optical distribution frame

### **3.1.2.2 PROJECT SUMMARY AND DESIGN PRINCIPLES FOR THE ADSS FIBER OPTICAL CABLE**

The basic information and design principles for the ADSS Fiber Optic in this project is only meant to offer general guidelines to the tenderers and is only meant to assist in the preparation of bids. Further details and more precise information are expected to be obtained during the site visits and route surveys which are mandatory.

#### **1. Proposed Links**

The Distribution stations outlined below are expected to be connected to their respective regional control centres via fiber optic cable. The concept is that ADSS cable be run from these stations up to the backbone node where there is existing fiber optic cable already to the control centre.

These stations (Distribution Stations) and their link ends (Origin) are as indicated in Table 1 following;

**Table 3-1 Estimated Distances**

REGION	DISTRIBUTION STATION	ORIGIN	APPROXIMATE DISTANCE (KM)
Nairobi	Industrial SS	Nairobi South SS	8
	Nyaga 33/11 SS	Ruiru S/S	15
		<b>SUB TOTAL</b>	<b>23</b>
Coast	Msambweni 33/11 kV	Mwabungo 33/11 kV	20
	Mwabungo 33/11kV	Galu SS	5
	Kanamai 33/11 kV SS	New Bamburi SS	18
	Watamu 33/11kV	Kakuyuni SS	15
	Kaloleni 33/11kV	Rabai SS	30
	Utange 33/ 11 kV SS	New Bamburi SS	12
	Shanzu33/ 11 kV SS	New Bamburi SS	5
	Mwatate 33/11 kV SS	Voi SS	20
	New Bamburi 132	Rabai SS	35
		<b>SUB TOTAL</b>	<b>160</b>
Mt Kenya	Embu East	Kutus	15
	Embu 33/11 kV	Kutus	25
	Karatina SS	Kiganjo 132	25
	Kerugoya SS	Karatina SS	20
	Ndarugu 33/11KV	Mangu SS	10

REGION	DISTRIBUTION STATION	ORIGIN	APPROXIMATE DISTANCE (KM)
	Othaya 33/11kV	Ruringu SS	21
	Githambo 33/11kV	Githambo 132	21
		<b>SUB TOTAL</b>	<b>137</b>
West Kenya	Kisian 33/11kV	Kisumu 132	14
	Kisumu East 33/11kV	Kisumu 132	16
	Elburgon 33/11kv	Soilo SS	10
	Njoro SS	Soilo SS	15
	Nyahururu 33/11kV	RumurutiSS	33
	Rongai SS	Soilo SS	5
	Mwariki SS	Nakuru Depot	5
	Eldoret Industrial 33/11kV	EldoretRivatex	8
	Kitale 33/11kV	Kitale 132	20
		<b>SUB TOTAL</b>	<b>126</b>
		<b>TOTAL</b>	<b>446</b>

## **2. Design Principles Of Proposed Aerial ADSS Fibre Cable**

The proposed Fibre cable shall be single mode, 48 core All-Dielectric Self-Supporting Cable (ADSS). This is a fibre cable that consists of the requisite number of tubes/elements as per the specified number of fibers and has fillers that are used to preserve the cable geometry. The tubes are further stranded around a dielectric central strength member and bound in a jacket.

The cable shall be designed and manufactured in accordance with the following standards:

- Fiber count: 48
- Fiber type: Single Mode
- Construction: Typical minimum span length of 150m
- Cable IEEE 1222
- Fiber IEC 60793, ITU-T G.652D
- Color code ANSI/EIA 359-A, IEC 60304

### **i. Installation of Aerial Fibre Cable**

- a. The cable installation shall be aerial on existing power lines. These lines are on wooden structures and on Concrete Poles and the ADSS cable shall be installed below the power line.
- b. The cable shall be installed at the highest point above the ground while maintaining KPLC working clearances. The construction method should endeavor to achieve a minimum clearance of four (4) feet away from the conductors subject to a minimum ground clearance of Eighteen (18) feet along the roads and a minimum clearance of Twenty Two (22) feet when crossing the road. Where such clearances may not be achieved the parties shall consult on the best solution.
- c. The cable shall be installed with internationally recommended standard to absorb wind loading and possible static charge.
- d. The installation shall be done under live line conditions except in instances where safe working clearance cannot be maintained and hence necessitating obtaining permission from the controllers for a dead line condition. Such situations will have to



be programmed for well in advance and tenderers are required to note such conditions during the route survey.

- e. The installation team shall undergo authorization interviews conducted by KPLC to ascertain their competence in working on live high voltage lines. No work shall commence until this competence is ascertained.
- f. It is not the intention of the KPLC to recommend any specific installation method but whichever method applied should be in accordance with the international standards, manufacturer's recommendation and within KPLC safety regulations. The bidder shall be required to provide information on the intended installation method & evidence of previous such works. This shall form part of the technical evaluation criterion.

**ii. Grounding of cable attachment parts**

Although the ADSS Fiber Optic cable does not require grounding, it is appreciated that it is mechanically attached to metallic parts such as the structure member, clamps, and rods which must be appropriately grounded for the safety of the personnel working on the cable in instances where the line remains energized.

**iii. Optic fibre approach cable (OFAC)**

The ADSS aerial cable shall terminate at first structure after the bus bar. This is normally a short distance from the building. An underground fibre optic cable shall be run from this structure to the building. This approach cable shall be of loose buffer type Optical Fibre Approach Cable (OFAC) of 48Fibres. The fibre optic approach cable shall be entirely suitable for laying through HDPE pipe in the cable ducts and on cable trays. The cable shall comprise of a tensile strength member, fibre support/bedding structure, core wrap/bedding and over all impervious jacket. No intermediate joints shall be permitted in any run of approach cable between its two termination points. The cable sheathing shall have additive to prevent rodent attack.

The fibre optic approach cable shall have a minimum outer jacket thickness of 3.0 millimeters and shall meet the following requirements.

- i. Fire retardant and no acid gas evolution.
- ii. Resistance to ultra-violet deterioration.
- iii. Anti-moisture penetration.
- iv. All other requirements will be same as ADSS.

#### iv. Installation materials

All bolts, nuts and clamps used during the construction shall conform to IEEE standards that apply to testing and performance of Hardware for All-Dielectric Self Supporting cable (ADSS). The bidder shall quote the standards used and test certificates for the material shall be provided together with the bid.

#### v. Splicing and testing

During the survey, locations for joints in every link shall be determined. These joints shall be preferably at the tension poles. These lengths shall determine the various drum lengths for every link. The design per section shall ensure that minimum numbers of joints are used. All joints shall be fusion spliced. The splice loss shall be equal to or less than 0.1db.

After all the terminations are done the cable shall be tested from ODF to ODF using the OTDR and the results tabulated.

#### vi. Optical Distribution Frames (ODFs)

This project is turnkey and bidders shall determine the locations of ODFs at the time of installation. Bidders shall also assess all the civil works to be carried out while accessing these ODFs at both terminals of the cable. The ODFs shall be wall mounted and supplied complete with patch panel, SM pig tails with FC connectors and splice tray cassettes.

The table below indicates the intended distribution of the wall mounted ODFs.

**Table 3-2 Distribution of ODF's**

REGION	DISTRIBUTION STATION	ORIGIN	48 Port ODFs
Nairobi	Industrial SS	Nairobi South SS	2
	Nyaga 33/11 SS	Ruiru S/S	2
		<b>SUB TOTAL</b>	<b>4</b>
Coast	Msambweni 33/11 kV	Mwabungo 33/11 kV	2
	Mwabungo 33/11kV	Galu SS	2
	Kanamai 33/11 kV SS	New Bamburi SS	2

REGION	DISTRIBUTION STATION	ORIGIN	48 Port ODFs
	Watamu 33/11kV	Kakuyuni SS	2
	Kaloleni 33/11kV	Rabai SS	2
	Utange 33/ 11 kV SS	New Bamburi SS	2
	Shanzu33/ 11 kV SS	New Bamburi SS	2
	Mwatate 33/11 kV SS	Voi SS	2
	New Bamburi 132	Rabai SS	2
		<b>SUB TOTAL</b>	<b>18</b>
Mt Kenya	Embu East	Kutus	2
	Embu 33/11 kV	Kutus	2
	Karatina SS	Kiganjo 132	2
	Kerugoya SS	Karatina SS	2
	Ndarugu 33/11KV	Mangu SS	2
	Othaya 33/11kV	Ruringu SS	2
	Githambo 33/11kV	Githambo 132	2
		<b>SUB TOTAL</b>	<b>14</b>
West Kenya	Kisian 33/11kV	Kisumu 132	2
	Kisumu East 33/11kV	Kisumu 132	2
	Elburgon 33/11kv	Soilo SS	2
	Njoro SS	Soilo SS	2
	Nyahururu 33/11kV	RumurutiSS	2
	Rongai SS	Soilo SS	2
	Mwariki SS	Nakuru Depot	2
	Eldoret Industrial 33/11kV	EldoretRivatex	2
	Kitale 33/11kV	Kitale 132	2
		<b>SUB TOTAL</b>	<b>18</b>
		<b>TOTAL</b>	<b>52</b>

### 3. Detailed Cable Characteristics

#### i. General

The ADSS optical cable shall be of non-metallic Aerial type designed for installation on 132 kV Power transmission lines as well as 66kV/33kV and 11kV distribution lines with minimum span lengths of 100 mts. The Bidder shall offer ADSS containing 48 Nos. of Single Mode (SM) optical fibers in conformity with ITU-T recommendations G-652D. The cable shall be designed to withstand all prevailing environmental conditions including the effects of high electric and magnetic fields produced by the proximity of live power conductors.

#### ii. Mechanical and Environmental specifications for 48 core SM (9/125) ADSS fiber optic cable

The cable shall be constructed from materials which have been technically proven and able to withstand the electrical and environmental conditions.

Table below gives the desired mechanical and environmental specifications for the ADSS Fiber Optic Cable for minimum performance characteristics.

Table 3.3 mechanical and environmental Specifications for 48 Core SM (9/125) ADSS Fiber Optic Cable

**Table 3-3**

ITEM	DESCRIPTION	MINIMUM REQUIREMENTS	TENDERER'S OFFER
1.	Fiber counts	48	
2.	Minimum Operating Load	6000 N	
3.	Minimum Bending Radius Installation  Long Term	20xO.D.   10xO.D.	
4.	Minimum. Compressive Loading	4000 N / 10 cm	

ITEM	DESCRIPTION	MINIMUM REQUIREMENTS	TENDERER'S OFFER
5.	Impact Resistance	4.4 J, 3 x 2 times	
6.	Twist (Torsion)	10 turns of 180° on 125xO.D.sample, both ways.	
7.	Storage Temperature Range	-50° C to +50° C	
8.	Operating Temperature Range	-40° C to +50° C	
9.	Core Fluid Penetration	1 m sample, 1 m water head for 24 Hrs	
10.	Distance Between Poles	Up to 100M	
11.	Warranty	15 years	
12.	UV Resistance		
13.	Outer Cable Markings	Property of Kenya Power & Lightening Company	
14.	Packing	Rolls for various sections to be determined by distance between section poles but not less than 1000M	
15.	Length marking	Every meter	
16.	Color of Cable	Black	
17.	Performance	Allowed attenuation per Km for the 9/125 micron single mode fiber optic cable 1) 1310 0.4 db/km 2) 1550 0.3 db/km	
18.	Fusion splice loss	Maximum allowed loss 0.1db	

**iii. General Specifications for the Optical Distribution Frame (ODF)**

**Error! Reference source not found.** Below gives the general technical specification for the Optical Distribution Frames.

**Table 3-4 General Specifications for ODF**

<b>ITEM</b>	<b>DESCRIPTION</b>	<b>MINIMUM REQUIREMENTS</b>	<b>TENDERERS OFFER</b>
1	Fiber optic wall mounted ODF	Fiber optic patch panel 48 ports SM wall mounted with enclosure	
		splice tray cassette,	
		48 pigtails terminated on FC connectors	
		Dust proof housing & lockable with key	

**iv. Fitting Materials**

All fitting materials shall conform to the approved standards by **IEEE1222**. The bidder shall attach type test certificates from the certifying bodies.

**v. Applicable Standards**

Unless otherwise specified in this specification, all requirements for individual components and completed cable shall mainly be in accordance with the following standard specifications;

IEEE std 1222, IEC 60794-4, IEC 60793-1, IEC 60793-2, IEC 60794-1, ITU-T G.652D, EIA 492A, EIA 472A, EIA 598 or ANSI/EIA 359-A-1985, ISO 9001 and ISO 14001.

**3.1.2.3 GUARANTEED TECHNICAL PARTICULARS AND STATEMENT OF COMPLIANCE**

*(This section is to be filled and signed by the Manufacturer for all clauses and submitted together with catalogues, brochures, drawings, and technical data and test reports for tender evaluation)*

**Table 3-5**

<b>DESCRIPTION</b>	<b>BIDDER'S OFFER</b>
1. Manufacturer's Name & Country of manufacture	
2. Type Reference/Model Number of cable offered	
3. Corrosion/ rust free fittings & components	
4. Environmental Conditions that cable can withstand as per technical specification.	
5. International recommended Standards adhered to.	
6. Maximum induction Voltage (kV) cable can withstand	
7. Cable loss per Kilometer (db)	
8. List of copies of Type Test Reports submitted (indicate Test Report Numbers, Testing Authority and contact addresses)	
9. List of Acceptance Tests to be witnessed by KPLC Engineers at the factory	
10. List of catalogues, brochures, technical data, drawings and customer sales records submitted to support the offer.	
11. Statement of compliance to specifications & guarantee	

.....  
**Manufacturer's Name, Signature, Stamp and Date**





### **3.1.3 FIBER OPTIC TOOLS & TEST EQUIPMENT SPECIFICATIONS**

A set of the requisite tools shall be provided with each lot as specified in the schedule of requirements. The tools shall conform to the minimum requirements below;

#### **3.1.3.1 SPLICING KIT**

The splicing kit shall consist of the basic set of implements necessary to carry out a splicing exercise and shall include the following at the minimum; a fusion type splicing machine, cleavers, strippers, batteries and power cord. The splicing machine shall be a 4-fiber ribbon splicer with high versatility. It shall be well suited for FTTXx applications and shall be of robust construction. Below are the features desired for the splicing machine;

- i. Rugged construction providing shock, dust and moisture resistance
- ii. Ability to withstand a 30” drop test.
- iii. Dual monitor position with automatic image orientation
- iv. Automatic arc calibration and ribbon fiber identification
- v. Auto-start tube heater
- vi. Color LCD display and anti-reflective coating for excellent visibility in bright sunlight
- vii. Simultaneous battery charge and splicer operation
- viii. Long life battery (up to 90 splice/heat cycles per charge)
- ix. Detachable work table incorporated into the transit case
- x. Data and video download software and splicer upgrade software to be included; software upgrades through PC application via the internet
- xi. Green friendly – RoHS & WEEE compliant

**Table 3-6 Technical Specifications for Splicing Machine**

S/NO.	DESCRIPTION	MINIMUM REQUIREMENTS	TENDERERS OFFER
1.	Type	Fusion Splicer	
2.	Applicable Fibers	Single-mode ITU-T G.652D	
3.	Fiber Count	Single, 2, 4	
4.	Cladding Diameter	125 $\mu$ m	
5.	Coating Diameter	Ribbon: 0.25mm to 0.4mm; Single: 250 $\mu$ m and 900 $\mu$ m	
6.	Fiber Cleave Length	10mm	
7.	Typical Average Splice Loss	0.05dB with SM, measured by cut-back method relevant to ITU-T and IEC standards	
8.	Splicing Time	20 seconds with standard single-mode fiber	
9.	Arc Calibration Method	Automatic with option of manual arc calibration function	
10.	Splicing Modes	100 preset and user programmable modes	
11.	Storage of Splice Result	Last 2000 splice results	
12.	Fiber Display	Both X and Y simultaneously with option of rear monitor display with automatic image orientation	
13.	Magnification	90X	
14.	Viewing Method	Dual cameras with 4.1 inch TFT color LCD monitor with anti-reflective coating	
15.	Operating Condition	0 to 5,000m above sea level, 0 to 85% RH, -10 to 50°C respectively	
16.	Mechanical Proof Test	1.96 to 2.25N	

S/NO.	DESCRIPTION	MINIMUM REQUIREMENTS	TENDERERS OFFER
17.	Tube Heater	Built-in tube heater with 30 heating modes complete with auto-start function	
18.	Tube Heating Time	50 seconds with FP-5 sleeve, 40 seconds with FP3 (40	
19.	Protection Sleeve Length	60mm, 40mm, micro	
20.	Splice/Heat with Battery	90 cycles with power save functions activated	
21.	Power Supply	Auto voltage selection from 100 to 240V AC or 10 to 15V DC	
22.	Terminals	USB 2.0 (USB-B type) for PC communication	
23.	Wind Protection	Maximum wind velocity of 15m/s. (34 mph)	
24.	Dimensions	136W x 161D x 143H (mm) / 5.3W x 6.3D x 5.6H (inches)	
25.	Weight	2.1 kg (4.6 lbs) with AC adapter	

### 3.1.3.2 TERMINATION KIT

The termination kit shall be a standard toolkit that contains a collection of essential tools needed for termination of Single Mode fiber optic cable of all connector styles (SC, FC, LC & ST). The case should be a carry like briefcase that is rugged and compact. The case shall be lined with a foam-padding material that keeps the tools safe, neat and in proper working order.

### 3.1.3.3 FAULT LOCATOR

The fault locator shall be an easy to use device of portable construction. It shall be of high performance in optical fiber troubleshooting functionalities with capability of locating fiber breaks and high loss events over long distances. It should be able to detect the fiber break location and display the results on an LCD screen.6 below gives the minimum requirements for the desired Fault Locator

**Table 3-7 Minimum requirements for Fault Locator**

S/No.	ITEM DESCRIPTION	MINIMUM REQUIREMENT	TENDERS OFFER
1.	Fiber Type	9/125 μm Single Mode	
2.	Wavelength	1550±20nm	
3.	Emitter Type	LD	
4.	Connector Type	SC	
5.	Pulse Width (ns)	10/20/40/80/160/320/640/1280/2560/5120/12400/24800 (auto-switch)	
6.	Max Output Power	100 mW	
7.	Max Measurement Range	130km	
8.	Distance Accuracy	+/- (0.8m + 0.001% x Distance)	
9.	Data Storage	999 measurements	
10.	Event Dead Zone	3 m	
11.	Power Supply	AC/DC adapter & Rechargeable NiHM Batteries	
12.	Battery Life	15,000 uses	
13.	Operating Temp.	-10°C to 55°C	
14.	Storage Temp	-20°C to 60°C	
15.	Humidity	<85% (non-condensing)	
16.	Communication Port	USB/Serial	
17.	Dimension (mm)	190L * 105W * 55H	

S/No.	ITEM DESCRIPTION	MINIMUM REQUIREMENT	TENDERS OFFER
18.	Net Weight	250g	

#### **3.1.3.4 OPTICAL TEST SET**

JDSU OLP-57 Optical Test Set complete with OLP 57 Power Meter, OLS 55 Laser Source & complete with optical accessories including case, power supply and adapter. An equivalent set shall also be acceptable. The connector styles supplied for use of the equipment shall be SC, FC, LC & ST complete with requisite test patch cords. The case should be a carry like briefcase that is rugged and compact. The case shall be lined with a foam-padding material that keeps the equipment safe, neat and in proper working order.

#### **3.1.3.5 RUGGED MAINTENANCE LAPTOPS**

Test Laptop with minimum of IP 54 enclosure, 8 hr battery life, 250 GB HDD, 8 GB RAM with minimum of 2 USB ports, DVD/ CD drive, Serial RS 232 port and SD port.

The laptop shall have wifi & bluetooth connectivity capability as well as a 3G SIM card slot. OS Windows 7 and 1 year warranty.

### 3.1.4 THE FIBER OPTIC TERMINAL EQUIPMENT SPECIFICATIONS

#### 3.1.4.1 INTRODUCTION

The fiber optic terminal equipment shall be based on user requirement and shall comprise of either switches or multiplexers.

**Table 7** below gives direction of the equipment required at each node.

**Table 3-8 Proposed Link Equipment**

<b><u>DISTRIBUTION SUBSTATIONS</u></b>			
	<b><u>Station</u></b>	<b>Link End SS</b>	<b>Proposed Link Equipment</b>
<b>NAIROBI REGION – STATIONS CONNECTED TO NCC</b>			
1.	Donholm 11kV	NAIROBI SOUTH	Switches
2.	Industrial 66/11kV	NAIROBI SOUTH	Switches
3.	Karen 66/11kV	NAIROBI WEST	Multiplexer
4.	Limuru 66/11kV	NAIROBI NORTH	Switches
5.	Athi River 33/11kV	EMBAKASSI	Multiplexer
6.	Machakos 33/11kV	EMBAKASSI	Multiplexer
7.	Nairobi Airport 66/11kV	EMBAKASSI	Switches
8.	Nyaga 33/11kV	RUIRU SS	Switches
9.	Muthurwa (new)	NAIROBI SOUTH	Switches
10.	EPZ	ATHI RIVER SS	Switches
<b>COAST REGION – STATIONS CONNECTED TO RABAI RCC</b>			

10.	Msambweni 33/ 11kV	Mwabungo 33/11kV	Switches
11.	Mwabungo 33/11kV	GALU SS	Switches
12.	Kanamai 33/11 kV SS	NEW BAMBURI	Switches
13.	Watamu 33/11kV	KAKUYUNI SS	Switches
14.	Kaloleni 33/11kV	RABAI SS	Switches
15.	Malindi 33/11kV	KAKUYUNI SS	Multiplexer
16.	Utange 33/ 11 kV SS	NEW BAMBURI	Switches
17.	Shanzu 33/11kV	NEW BAMBURI	Switches
18.	Mwatate 33/11 kV SS	VOI SS	Switches
19.	NEW BAMBURI	RABAI SS	Multiplexer
<b>MT KENYA REGION - STATIONS CONNECTED TO KIGANJO RCC</b>			
19.	Embu East SS	KUTUS SS	Switches
20.	Embu 33/11kV	KUTUS SS	Switches
21.	Karatina SS	KIGANJO 132	Switches
22.	Kerugoya SS	KARATINA SS	Switches
23.	Ndarugu 33/11KV	MANGU SS	Switches
24.	Meru 33/11kV	MERU 132	Switches
25.	Othaya 33/11kV	RURINGU SS	Switches
26.	Githambo 33/11kV	RURINGU SS	Switches

<b>WEST KENYA REGION - STATIONS CONNECTED TO LESSOS RCC</b>			
27.	Kakamega 33/11kV	MUSAGA SS	Multiplexer
28.	Kericho 33/11kV	CHEMOSIT SS	Multiplexer
29.	Kisian 33/11kV	KISUMU 132	Switches
30.	Kisii 33/11kV	KISII 132	Switches
31.	Kisumu East 33/11kV	KISUMU 132	Switches
32.	Obote Rd 33/11kV	KISUMU 132	Multiplexer
33.	Elburgon 33/11kV	SOILO SS	Switches
34.	Gilgil 33/11kV	LANET SS	Multiplexer
35.	Soilo	LANET SS	Multiplexer
36.	Njoro 33/11 kV SS	SOILO SS	Switches
37.	Nyahururu 33 /11 kV	RUMURUTI SS	Switches
38.	Rongai 33/11 kV SS	SOILO SS	Switches
39.	Mwariki 33/11 kV SS	NAKURU DEPOT	Switches
40.	Eldoret Industrial 33/11kV	RIVATEX	Switches
41.	Kitale 33/11kV	KITALE 132	Switches
42.	Kapsabet 33/11kV	LESSOS	Switches
43.	Turkwel 220 kV	LESSOS	PLC Terminal Equipment

The links shall be setup as point to point links, where service carried on the equipment shall be dropped at the backbone node for integration into KPLC's existing infrastructure. This scope shall still fall within that of the contractor.



The services to be carried on the multiplexers shall be;

1. SCADA IEC 60870-5-104 data, requiring Ethernet access
2. KPLC Corporate Office data, requiring Ethernet access
3. 2 Wire Telephony for PAX extensions requiring P0 (64kbps) 2 wire connection to the equipment. This item 3 is not a requirement for where switches shall be in use.

### 3.1.4.2 PROJECT SUMMARY & DESIGN PRINCIPLE

The links shall be point to point with integration of services outlined in 3.1 above at the backbone substation.

The concept is outlined in figure 1 below;

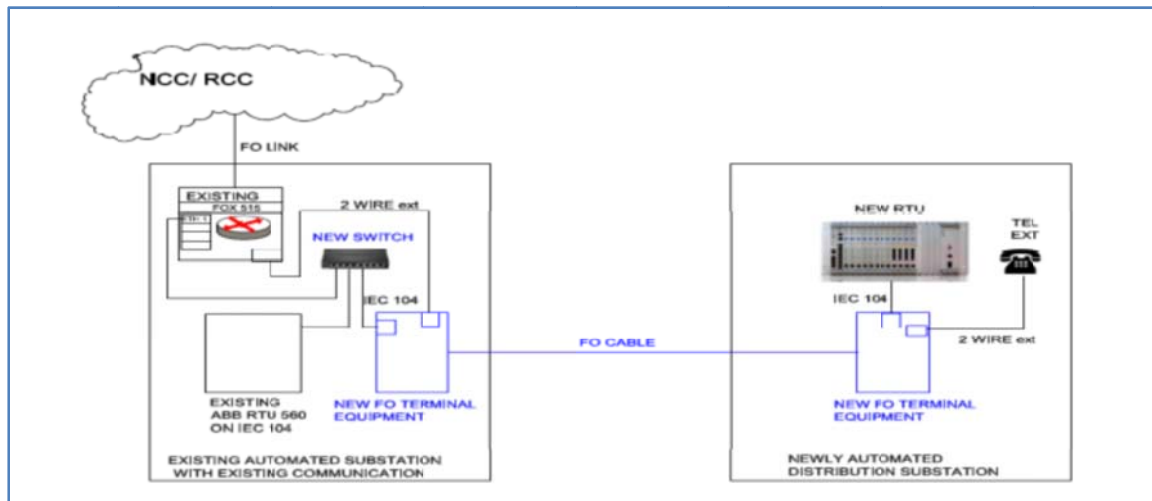

**Figure 3-1 SCADA, DATA & Telephony Integration**

### 3.1.4.3 SCADA & TELEPHONY COMMUNICATION INTEGRATION OF NEW DISTRIBUTION STATION INTO KPLC SCADA SYSTEM:

When the Distribution Substation being automated is linked to an existing already automated substation via a fiber link, the integration proposal shall require the following;

1. Point to Point FO terminal equipment, 2 UNITS PER LINK, capable of handling 64KBps speech channel where required and Ethernet data traffic, preferably capable of VLAN configuration

2. A Ruggedcom or equivalent switch at the existing station
3. All necessary accessories & configuration to achieve the link above in fig 1 above.

### 3.1.4.4 MULTIPLEXER REQUIREMENTS

**Table 3-9 Guaranteed technical particulars (multiplexer)**

	<i>Minimum Requirements</i>	<i>Tendered Offer</i>
	<b><i>Make and Model</i></b>	
	<i>Equipment Manufacturer</i>	Tenderer to state
	<i>Make and Model</i>	Tenderer to state
<b>A.</b>	<b>General Features</b>	
	Four E1 data ports	
	Four Ethernet ports	
	Access units for P0 (64kBps), n x P0 ,E1 or n x E1 services.	
	Can support Drop/Insert features in/out of the P0 &E1	
	Can support E1 to E1 channel pass through and n x P0 cross connect between the E1's	
	STM-1 Optical aggregate up to 140 MBps	
<b>B.</b>	<b>Interfaces</b>	
	Data Rate 2.048 Mbps on E1 on 4 wire Krone Block or RJ 11 connector	
	Connector RJ-45 for Ethernet connectivity upto 100Mbps per port with VLAN configuration capability	
	FXO & FXS for 2 wire P0 (64Kbps) telephony extension from PAX	
	E1 interface complies with: ITU G.703, G.704, G.706, G.732 for TDM & SDH compatibles Complies ITU Jitter G.823 & G.824	
	Ethernet Range of up to 300 feet	

	Timeslot assignment is programmable, allowing data from each data port and from the sub-E1 port to be placed automatically into consecutive timeslots. Alternatively, timeslots can be allocated manually, at user discretion.	
	Clock source can be taken from the recovered receive clock signal, an internal oscillator, one of the data ports, or the sub-E1 port.	
<b>C</b>	<b>SFP aggregate modules (UPLINK)</b>	
	Required ar per link lengths	
	Minimum capacity of STM-1	
	Single mode, 9/125 dual fiber, LC connector	
	TX power (take into account the standard cable and splice loss for 9/125 single mode.)	Tenderer to state
	Rx sensitivity	Tenderer to state
	20 Meters Single mode patch cords with LC to FC connectors	
<b>D.</b>	<b>Management:</b>	
	Out-of-band via V.24 (RS232) supervisory port and IP port	
	SNMP internal agent,	
	Front Panel Status Display	
	In band management remote access using spare bits or selected Timeslot	
	Maintenance capabilities include <ul style="list-style-type: none"> <li>1. User-activated local loop backs</li> <li>2. Remote loop backs at the E1 main link, sub-E1 and data ports.</li> </ul>	
	Logging facility for E1 /Ethernet network performance monitoring and most recent alarms	

	Alarm mask configurable for any alarm	
<b>E.</b>	<b>Power Source</b>	
	Equipment shall be capable of being supplied through 240 Volts AC and -48Volts DC	
	Power Consumption by the Multiplexers	Tenderers to state
<b>F.</b>	<b>3) Other requirements</b>	
	Rack Mountable 19 inch with mounting brackets	
	Height (Tenderers to state)	
	Depth (Tenderers to state)	
	Weight (tender to state)	
<b>G.</b>	<b>Environment</b>	
	Temperature 5°C to 50°C	
	Humidity Up to 90%, non-condensing	
	Altitude up to 3000m ASL	
<b>H.</b>	<b>Type approval &amp; Warranty</b>	
	Warranty for 1 year	

### 3.1.4.5 UPLINK SWITCH REQUIREMENTS

**Table 3-10 Guaranteed technical particulars (Switch)**

	<i>Minimum Requirements</i>	<i>Tendered Offer</i>
	<i>Make and Model</i>	
	<i>Equipment Manufacturer</i>	Tenderer to state

	5) <i>Make and Model</i>	6) Tenderer to state
<b>A.</b>	<b>Uplink – Ethernet Interface</b>	
	Minimum of two RJ45 & two SFP (single mode) Ports	
	Uplink Capacity of 10/100/1000 MBps	
	Auto – negotiation Ethernet function	
	Auto MDI/ MDIX function	
	Full/ Half Duplex select ability	
	Flow Control Functionality IEEE 802.3x	
<b>B.</b>	<b>Down Link Ethernet Interface</b>	
	Minimum of four RJ45 Connector Ports	
	Uplink Capacity of 10/100 MBps	
	Auto – negotiation Ethernet function	
	Full/ Half Duplex select ability	
	Flow Control Functionality IEEE 802.3x	
<b>C</b>	<b>Software Functions</b>	
	Support Link Aggregation of a minimum of 2 trunk groups	
	Support RSTP IEEE 802.1w standard & enabling/ disabling RSTP on each port	
	Supports VLAN setup with upto 10 VLANs working simultaneously, IEEE 802.1Q VLAN standard with support also for Port based VLAN	
	Supports 2 level access rights User account Management as well as role based user authentication for Telnet and SSH	
<b>D.</b>	<b>Management:</b>	
	RS 232 Console Port supplied complete with requisite cable	
	SNMP / Ethernet Port with front panel RJ 45 connection for Telnet, SSH and/or Web based utility management	

<b>E.</b>	<b>Power Source</b>	
	Equipment shall be capable of being supplied through 240 Volts AC and -48Volts DC	
	Power Consumption by the Uplink switches	Tenderers to state
<b>F.</b>	<b>7) Other requirements</b>	
	Rack Mountable 19 inch with mounting brackets	
	Height (Tenderers to state)	
	Depth (Tenderers to state)	
	Weight (tender to state)	
	20 Meters Single mode patch cords with LC to FC connectors	
	Requisite single mode SFP modules to achieve link	
<b>G.</b>	<b>Environment</b>	
	Temperature 5°C to 50°C	
	Humidity Up to 90%, non-condensing	
	Altitude up to 3000m ASL	
<b>H.</b>	<b>Type approval &amp; Warranty</b>	
	Warranty for 1 year	

### 3.1.4.6 STATION SWITCH REQUIREMENTS

The function of this switch shall be purely to connect RTU from distribution station into the existing SCADA network at the backbone for onward transmittal of both to the relevant RCC

**Table 3-11**

	<i>Minimum Requirements</i>	<i>Tendered Offer</i>
	<b><i>Make and Model</i></b>	
	<i>Equipment Manufacturer</i>	Tenderer to state
	<i>Make and Model</i>	Tenderer to state
<b>A.</b>	<b>Transmission Rate</b>	
	Transmission Rate of 10/ 100Mbps	
<b>B.</b>	<b>Interfaces</b>	
	Minimum of four RJ45 electrical Interface ports	
<b>C.</b>	<b>Management:</b>	
	RS 232 Console Port supplied complete with requisite cable	
<b>D.</b>	<b>Power Source</b>	
	Equipment shall be capable of being supplied with 48Volts DC	
	Power Consumption by the station switch	Tenderers to state
<b>E.</b>	<b><i>Other requirements</i></b>	
	35mm DIN rail mounted	
<b>F.</b>	<b>Environment</b>	
	Minimum Temperature range of -10°C to 60°C	
	Minimum of IP 40 Ingress Protection class	
	Fanless Operating Condition	

	Heavy Duty cast aluminum enclosure or equivalent	
<b>G.</b>	<b>Type approval &amp; Warranty</b>	
	Warranty for 1 year	

### 3.1.5 THE FIBER OPTIC CABLE & TERMINAL EQUIPMENT SPARES REQUIREMENT

Making reference to the fiber & terminal equipment installed, the spares required shall be calculated as follows;

**Table 3-12**

No	Description	Quantity	%age of Spares	Spares List
1	ADSS FO Cable	426 KMS	5%	22 KMS
2	Multiplexers	20	10%	2
3	Uplink Switches	68	10%	7
4	Station Switches	36	10%	4
5	ODFs	52	10%	5
6	FC – LC Patch Cords	52	20%	10
7	SFP Modules (20, 40, 60 & 80 KMS)	2 of each		8

### 3.1.6 TESTING

- Factory Acceptance Tests (FAT) Systems shall pass agreed set out tests before they may be shipped to site. KPLC shall witness FATs unless he waives this in writing. FAT preparation costs shall be borne by contractor except transport and accommodation. FAT shall be carried by two KPLC staff for 5 days.
- Site Acceptance Tests (SAT) Systems shall pass agreed set out tests before they may be put into operation and before they are Taken Over



The System will be accepted by KPLC if both:

- The System and all items of equipment have successfully completed all the specified tests
- All failures, problems and reservations noted during the tests have been corrected to the satisfaction of KPLC.
- If either of these conditions has not been complied with, then the necessary corrective action shall be agreed between the Contractor and KPLC.

### **3.1.7 TRAINING**

The Contractor shall provide 2 weeks training for four KPLC staff at the supplier's manufacturing premises on each Telecommunication type of equipment supplied and on site during installation works. All training costs shall be borne by Contractor except travel to manufacturers place and accommodation which shall be borne by KPLC. The scope of each service shall be given. The training content shall be subject to approval of the project Manager.

## **3.2 RADIOS**

### **3.2.1 THE TECHNICAL SPECIFICATIONS**

Technical specifications describe the basic requirements for goods. In addition to the information and documentation in the Tender Document regarding the technical aspects of this tender, all Tenderers shall comply with the following -

#### **3.2.1.1 GENERAL REQUIREMENTS**

- i. Technical documentation shall be in English language. The specific items on offer shall be marked clearly for the goods they intend to supply.

- ii. The Tenderer shall submit the Schedule of Guaranteed Technical Particulars (GTP) completed by the Manufacturer. In submitting the GTP, cross-references should be made to the documents submitted.
- iii. Deviations from the tender specifications, if any, shall be explained in detail in writing, with supporting data including calculation sheets, detailed drawings and certified test reports and submitted together with the Tender. In submitting the deviations, cross-references should be made to the documents submitted. Kenya Power reserves the right to reject the goods if such deviations shall be found critical to the use and operation of the goods.
- iv. Detailed contact information including title, e-mail, facsimile, telephone or any other form of acceptable communication of the testing and standards body used shall be provided.
- v. Where Type Test Certificates and their Reports and or Test Certificates and their Reports are translated into English, all pages of the translations must be signed and stamped by the testing authority.
- vi. A Copy of the manufacturer's valid quality management system certification i.e. ISO 9001 shall be submitted for evaluation. For locally manufactured goods this requirement is not mandatory but all Test Reports and Certificates shall be certified by the Kenya Bureau of Standard (KEBS) or its appointed agent(s), in which case a letter of Accreditation must be submitted.
- vii. In all cases where the level of galvanizing and painting is not specifically stated in the detailed Technical Specifications, the general requirement shall be for a uniform coating of thickness not less than 80 microns.
  
- viii. Suppliers are required to provide information on proper representative(s) and or workshop for back-up service and or repair and maintenance including their names, telephone, facsimile, e-mail, physical and postal addresses, along with their offers.

### **3.2.1.2 DIRECT REPLACEMENTS**

These radios shall be for direct replacement of existing equipment's which has been vandalized, burnt or damaged in any way and shall be mounted on existing cabinets.

**3.2.1.2.1 The supplier shall install, test and commission the supplied radios**

**3.2.1.2.2 The radios shall be vendor and type specific to achieve compatibility.**

MDS SD4 remote radios shall be used.

Specification shall include:

**i. General**

- a. Frequency Bands: 330 to 400 MHz
- b. Data Rate: 9600 bps @ 12.5 kHz Channel Spacing
- c. Frequency Programmability: 6.25 kHz increments
- d. Operational Modes: Simplex, half-duplex
- e. Modulation: Digital / CPFSK

**ii. Transmitter**

- a. Frequency Stability: +/- 0.00015% 1.5 ppm
- b. Carrier Power: 0.1 to 5 Watts Programmable
- c. Carrier Power Accuracy: Normal +/-1.5 dB
- d. Duty Cycle: Continuous
- e. Output Impedance: 50 Ohm

**iii. Interfaces**

- a. Serial COM1: RS-232, DB-9
- b. Serial COM2: RS-232, RS-485 DB-9
- c. Ethernet: 10/100 BaseT, RJ 45
- d. Antenna: TNC Female

**iv. Receiver**

- a. Type: Double Conversion Super heterodyne
- b. Bit Error Rate: BER  $1 \times 10^{-6}$  @ -112 dBm Typical
- c. Frequency Stability: +/- 0.00005% (0.5 ppm)
- d. Adjacent Channel (EIA): 60 dB nominal

### 3.2.1.3 Radio Details

**Table 3-13** Radio Details

Site	Frequency	Qty
Steel Billets	335-345 MHZ	1
Kikuyu	360-370 MHZ	1

### 3.2.2 NEW INSTALLATIONS

**3.2.2.1 The supplier shall deliver, install and commission point to point radios as specified in this documents.**

**3.2.2.2 The supplier shall carry out radio path propagation profiling, determining the optimal performance. Details about radio equipments, antenna size, and performance and availability calculations shall be submitted.**

**3.2.2.3 The supplier shall construct Communication towers at sites described in the bill of quantities.**

#### 3.2.2.4 Radio Detailed specifications

- i. Architecture: Small Form Factor ODU Unit with embedded antenna and Connectorized for External Antenna
- ii. IDU to ODU Interface: Enhanced Outdoor CAT - 5e cable; Maximum cable length: 100 m
- iii. Capacity: 50Mbps aggregate Ethernet net throughput and up to 2 E1s / T1, minimum.
- iv. Range: Up to 60 km minimum
- v. Encryption: AES 128
- vi. VLAN: Supported
- vii. Band: 5.9 GHz Universal 5.730 - 5.950 GHz
- viii. Safety: ETSI EN/IEC 60950 -1, EN/IEC 60950 - 22
- ix. EMC: ETSI EN 300 386, EN 301 489 - 1, EN 301 489 - 4
- x. Operating Temperatures - 35°C - 60°C / - 31°F – 140°F
- xi. Power: 48 VDC, Power Feeding: Power provided over ODU - IDU cable

### 3.2.2.5 Link Details

**Table 3-14 Link Details**

	Link		Site1	Tower,	Site2	Tower
Lot	Marura- Naivasha		Naivasha	Existing, 20m	Marura	20m
	Kihoto- Naivasha		Naivasha	Existing, 20m	Kihoto	20m
	Chemosit- Mogosiek		Chemosit	30m	Mogogosiek	20m
	Chemosit- Sotik		Chemosit	30m	Sotik	20m
	Cheptulu- Kakamega		Kakamega	20m	Cheptulu	20m

### 3.2.2.6 Enclosures

#### 3.2.2.6.1

All equipment shall be housed in single sheet steel cubicles segregated into compartments by sheet steel separators, and of height of 9 U and width of 840mm. The cubicle shall be wall mounted.

#### 3.2.2.6.2

Cubicles shall have a hinged front cover with locking facilities, giving full access to all components and cable connections. The front cover shall be solid and transparent.

#### 3.2.2.6.3

The cubicles shall satisfy the requirements of corrosion protection as specified and shall be ventilated and protected to class IP42.

#### **3.2.2.6.4**

Where ventilation openings are provided these shall be fitted with drip-proof louvers and fine mesh wire or perforated screens to exclude small insects and vermin.

#### **3.2.2.6.5**

A gland plate shall be provided sufficient for all incoming and outgoing cables including spare capacity

### **3.2.3 COMMUNICATION TOWERS**

#### **3.2.3.1 TECHNICAL SPECIFICATIONS**

Technical specifications describe the basic requirements for goods. In addition to the information and documentation in the Tender Document regarding the technical aspects of this tender, all Tenderers shall comply with the following -

#### **3.2.3.2 Part A - General Requirements**

1. Technical documentation shall be in English language. The specific items on offer shall be marked clearly for the goods they intend to supply.
2. Deviations from the basic requirements, if any, shall be explained in detail in writing with the offer, with supporting data including calculation sheets, detailed drawings and certified test reports. The Procuring Entity reserves the right to reject the goods if such deviations shall be found critical to the use and operation of the goods.
3. The Supplier shall submit a commentary on the Guaranteed Technical Particulars (GTP) as well as a Statement of Compliance to Technical Specifications. In submitting the GTP and Statement of Compliance, the Suppliers and or Manufacturers should provide cross-references to the documents submitted.

4. The Statement of Compliance shall be in table form, and shall cover in detail, all clauses of the specification(s).
  5. Detailed contact information including title, e-mail, facsimile, telephone or any other form of acceptable communication of the testing and standards body used shall be provided.
  6. Where Type Test Certificates and their Reports and or Test certificates and their Reports are translated into English, all pages of the translations must be signed and stamped by the testing authority.
  7. The Manufacturer's Declaration of Conformity to reference standards and copies of quality management certifications including valid ISO 9001: 2000 shall be submitted for evaluation. For locally manufactured goods this requirement is not mandatory but all Test Reports and Certificates shall be certified by KEBS or its appointed agent(s), in which case a letter of Accreditation will be required.
  8. In all cases where the level of galvanizing and painting is not specifically stated in the detailed Technical Specifications, the general requirement shall be for a uniform coating of thickness not less than 80 microns.
  9. Suppliers are required to provide information on proper representative(s) and or workshop for back-up service and or repair and maintenance including their names, telephone, facsimile, e-mail, physical and postal addresses, along with their offers.
  10. Suppliers shall be aware of requirements and regulations guiding Design, Supply and installation of radio masts by the Communication Commission of Kenya and relevant local authorities.
  11. It shall be the responsibility of the suppliers to obtain necessary permits and approval from local authorities and the regulator, Communication Commission of Kenya.
  12. The supplier shall submit detailed drawings for approval.
- Detailed Technical Specifications for the goods appear hereafter.

### **3.2.3.3 Part B – Detailed Technical Specifications**

- 1.0 The Towers shall be designed to withstand basic operational wind speed of 40 m/s
- 2.0 Maximum deflection at the highest position under the most adverse loading of is 60% of the maxim allowable limit of 0.5 degrees.

- 3.0 The tower elements will primarily consist of angular members with optimized and manufacturing and fabrication efficiencies and speeds. A working/service platform shall be provided.
- 4.0 Bolts and nuts shall be manufactured with high strength A 325 according to ASTM.
- 5.0 The following accessories and safety equipment shall be provided with the towers;
  - 5.1) A lighting arrestor of 1.5 meter length for installation at the top of the tower.
  - 5.2) 3” diameter 3 meter long poles for mounting bracket sets
  - 5.3) Suitably designed climbing ladder
- 6.0 Tower earthings system shall be to design specifications and shall conform to international standards and IEEE specifications to earthing telecommunications masts.
- 7.0 Aviation warning Lights (AWL) using 240 VAC shall be 100,000 hours life and necessary cables for lighting from substation building shall be provided.
- 8.0 The towers are to be installed in various parts of the country and foundation designs shall take into consideration terrain categories and quote appropriately.
- 9.0 The tower shall be designed to sustain a wind loading on tower equipment as required by BS specification CP3# Chapter V: part 2
- 10.0 The tower shall be designed and constructed to a foundation structure as required by BS specification BS 8110
- 11.0 All welding and steel inspection processes are backed by AISC Certification/or internationally accepted standard and ISO 9001
- 12.0 Towers should be designed to meet or exceed the latest EIA/TIA code requirements.
- 13.0 Towers should be fabricated in a factory using fully automated machines.



**Table 3-15**

Minimum Requirement	Tenderers offer
<ol style="list-style-type: none"> <li>1. Towers <b>MUST</b> be triangular. Towers of exceptional strength, ease of implementation, and low maintenance</li> <li>2. All welding and steel inspection processes are backed by AISC Certification and ISO 9001.</li> <li>3. Every product should be designed to meet or exceed the latest EIA/TIA code requirements.</li> <li>4. The steel used in the manufacture of the towers should be of grade 350WA and the bolts should be of grade 8.8.</li> <li>5. Tower sections should be supplied galvanized. The galvanizing thickness should be equal or less than 5mm.</li> <li>6. Assembles with basic tools (such as pulley block, rope, torque wrench)—no cranes or any other heavy or specialized equipment required.</li> <li>10. Should have no welding, no drilling—all Tower connections are bolted.</li> <li>11. Modular design with 2-4 m legs.</li> <li>12. For 30 m Tower height – in 2-4 m increments up to the end of the tapered section, thereafter in 2-4 m increments up to the Top.</li> <li>13. For 15 and 20 Meter Tower height - in 2-4 Meters increment parallel sections</li> </ol>	
<p><b>Parallel Light Weight Tower (15-30m Tower):</b></p> <p>The parallel light weight tower has the following physical properties.</p> <ol style="list-style-type: none"> <li>1. height -15-30m</li> <li>2. parallel section <b>MUST</b> be -15 -30m</li> <li>3. parallel face width- 1.5 m</li> <li>4. Tower heights- in 2-4 m increments up to top</li> </ol>	

<b>Foundation Designs</b>				
<i>The table below gives approximate standard foundation design quantities for various tower heights;</i>				
<b>Tower Height</b> <i>(m)</i>	<b>Concrete volume</b> <i>( m<sup>3</sup> )</i>	<b>Rebar</b> <i>(kg)</i>	<b>Excavation</b> <i>( m<sup>3</sup> )</i>	<b>Backfill</b> <i>( m<sup>3</sup> )</i>
<b>15</b>	<b>3.2</b>	<b>220</b>	<b>9.8</b>	<b>7.3</b>
<b>20</b>	<b>3.6</b>	<b>250</b>	<b>11.7</b>	<b>7.6</b>
<b>30</b>	<b>6.6</b>	<b>500</b>	<b>22</b>	<b>14.6</b>
<b>Antenna Loading Capacity</b>				
<b>Basic wind speed</b>	40 m/s			
<b>Terrain category</b>	2			
<b>Altitude</b>	0 m			
<b>False datum</b>	0 m			
<b>Antenna loading</b>	5.4 m <sup>2</sup> over the top 4.5m of the Tower			

## CHAPTER FOUR

---

### **4 48 VDC CHARGERS AND BATTERIES**

#### **THE TECHNICAL SPECIFICATIONS**

Technical specifications describe the basic requirements for goods. In addition to the information and documentation in the Tender Document regarding the technical aspects of this tender, all Tenderers shall comply with the following -

#### **4.1 GENERAL REQUIREMENTS**

Technical documentation shall be in English language. The specific items on offer shall be marked clearly for the goods they intend to supply.

The Tenderer shall submit the Schedule of Guaranteed Technical Particulars (GTP) completed by the Manufacturer. In submitting the GTP, cross-references should be made to the documents submitted.

Deviations from the tender specifications, if any, shall be explained in detail in writing, with supporting data including calculation sheets, detailed drawings and certified test reports and submitted together with the Tender. In submitting the deviations, cross-references should be made to the documents submitted. Kenya Power reserves the right to reject the goods if such deviations shall be found critical to the use and operation of the goods.

Detailed contact information including title, e-mail, facsimile, telephone or any other form of acceptable communication of the testing and standards body used shall be provided.

Where Type Test Certificates and their Reports and or Test Certificates and their Reports are translated into English, all pages of the translations must be signed and stamped by the testing authority.

A Copy of the manufacturer's valid quality management system certification i.e. ISO 9001 shall be submitted for evaluation. For locally manufactured goods this requirement is not mandatory

but all Test Reports and Certificates shall be certified by the Kenya Bureau of Standard (KEBS) or its appointed agent(s), in which case a letter of Accreditation must be submitted.

In all cases where the level of galvanizing and painting is not specifically stated in the detailed Technical Specifications, the general requirement shall be for a uniform coating of thickness not less than 80 microns.

Suppliers are required to provide information on proper representative(s) and or workshop for back-up service and or repair and maintenance including their names, telephone, facsimile, e-mail, physical and postal addresses, along with their offers.

## **4.2 DETAILED TECHNICAL SPECIFICATIONS**

### **4.2.1 GENERAL REMARKS**

Kenya Power intends to procure 48 VDC Supplies for its 45 critical telecommunication sites across the country to meet growing demand, increase standby time, reliability, and effective remote monitoring.

### **4.2.2 SCOPE**

This specification gives minimum requirements for 48 VDC Chargers, Batteries and DC control and distribution Boards, to be supplied at various telecommunications sites spread across the country. This shall include Design, installation works, testing, and commissioning works.

The supplier may request, at his own cost, to conduct a site survey to ascertain any details that

### **4.2.3 RECTIFIER/ BATTERY CHARGER**

#### **4.2.3.1 General**

A 100% duty charger, having boost and float capabilities shall be supplied.

The battery charger is to be solid state, SCR technology or swicthmode technology, microprocessor controlled. It must be designed to float or equalize batteries using a constant voltage, current limiting logic. Timer and controls must be static.

Each charger unit shall be capable of supplying the initial charging requirements, boost charging the battery subsequent to an emergency discharge and supplying the maximum load whilst on float. The batteries shall be recharged within 12 hours to a fully charged condition.

The charger shall be equipped with a “Surveillance” device, this device shall be fed by its own DC-DC supply coming from the battery and operate with a different firmware than the main controller. The “Surveillance” device shall communicate with the control board through an internal communication bus network, should any of the two devices fail, the healthy circuit shall de-energize a form ‘C’ contact for immediate intervention.

The charger shall have a built-in, dual Electronic Low Voltage disconnect device (ELVD) for battery protection.

The charger shall have an option to connect at least two Low Voltage Disconnect contactors of upto 1600A.

Blocking diode with full redundancy shall be provided in the output circuit of each

Charger to prevent current flow from the D.C. Battery into the Charger.

Have RFI- Interference protection at least equal to mode "N" according to DIN VDE 0875.

If required, 48-24VDC converter shall be integrated into the charger and shall be possible to manage through the controller. The capacity shall be 10A. The 24VDC output shall clearly be marked on the D.C distribution board. The 48 VDC output provision shall still be maintained through spare capacity as required elsewhere in this specification.

The rectifier/battery charger may be supplied by single phase A.C input upto 50A DC output. 100ADC and 200ADC output, shall have **three phase AC input.**

#### **4.2.3.2 The Controller**

The controller shall:

Be hot swappable.

Have minimum and maximum operating voltages as 20VDC and 70VDC respectively to ensure it functions correctly under extreme conditions.

Be capable to monitor, manage and utilise at least two battery sets.

Be capable to control at least 35 rectifier modules.

Have LCD display for alarms/events with date and time stamp, Input AC Voltage and current measurements without external equipment, DC Voltage and current measurements for battery and Load.

Have non-volatile storage of alarms/events with time and date stamp, exceeding 350 entries.

Control and provide individual rectifier information.

Shall have inbuilt, automatic battery testing capability without disconnecting the load. Tests shall include but not limited to:

- -Constant current, capacity, real load, and time based battery tests.
- Natural battery test (using the opportunity of a mains failure)
- Shall have configurable charging functions including:
  - -Float charge
  - -Boost charge
  - -Equalize
  - -Event controlled charge
- Shall have the following supervision functions:
  - -Back-up time
  - -Middle point voltage supervision
  - -String current comparison
  - -Block voltage measurement
  - -Redundancy and power capacity supervision

#### **4.2.3.3 Rectifiers**

The rectifiers units shall have:

Modular construction, hot swappable and easy to remove/replace from front of the cubicle.

A means of isolating from the main system shall be independently protected from a.c input surges of 6000V at 3000A per IEEE 587 standard. Surge protection assures performance under adverse conditions.

Automatic load sharing ensuring equal power distribution from no load to full load between modules in parallel applications, to within +-5%.

Active power-factor correction shall be greater than 0.99.

Shall have output current indication on the front.

Input surge protection device shall be located in a convenient place, at the back plane, to ensure ease of access and replacement.

#### **4.2.3.4 Output Voltage**

Output voltage to be temperature compensated. Maximum allowed voltage is 59VDC and the minimum allowed voltage is 47 VDC.

Have the possibility to adjust and set the charger output voltage and current limit values separately for each operating mode of the charger. The adjustable range shall be the limits of maximum and minimum outputs.

Soft start feature shall be provided to build up the voltage to the set value slowly within fifteen seconds.

The chargers shall have load limiters, which shall cause, when the voltage control is in automatic mode, a gradual lowering of the output voltage when the DC load current exceeds the load limiter setting of the Charger.

The load limiter characteristic shall be such that any sustained overload or short circuit in DC system shall neither damage the Charger nor shall it cause blowing of any of the charger fuses.

The Charger shall not trip on overload or external short circuit. After clearance of fault, the Charger voltage shall build up automatically when working in automatic mode.

During Float charging, the Charger output voltage shall remain within  $\pm 0.5\%$  of the set value for AC input voltage variation of  $230 +10\%$ ,  $-15\%$  frequency variation of  $\pm 5\%$ , a combined voltage and frequency (absolute sum) variation of  $10\%$  and a continuous DC load variation from  $5\%$  to full load.

Energizing the Charger with fully charged battery connected plus  $10\%$  load shall not result in output voltage greater than  $110\%$  of the voltage setting. Time taken to stabilize, to within the specified limits in clause 3.4 (e), shall be less than five seconds.

All potentiometers shall be electronically locked to contain the various parameters within allowable limits even if the setting position of potentiometers is changed to extreme positions.

#### **4.2.3.5 Charging**

The charging process shall be constant voltage with float and boost charging capabilities. Equalize circuit must be embedded as such it can be activated or deactivated as per the battery specifications.

The charging process shall be automatic and microprocessor controlled.

The charger shall automatically switch into the boost charging mode when the battery has discharged below a preset value.

During Boost charging, the Battery Chargers shall operate on constant current mode with maximum current limiter setting (When automatic regulator is in service).

Equalize commands and timing must be available via the communication port and must also be available in manual mode.

Automatic equalize activation modes must be based on: Time, low voltage, charger start, AC fail, AH count, with an adjustable delay of up to 72 hours.



Automatic equalize termination modes must be based on: Time, battery voltage, charger current, AH counts and temperature. All automatic modes must be protected by a timer.

The charger shall be equipped with two additional charge modes: Automatic antidepressant equalize mode for Ni-Cd batteries and a fully manual mode for the commissioning charge (constant current mode) of batteries.

Full charge detection shall be done accurately by monitoring change in battery voltage and change in temperature.

Have operating characteristic in accordance with DIN 41772/DIN 41773. The charging characteristic shall be to the approval by Kenya Power.

However, the battery manufacturers recommendations for float/trickle, equalizing and boost charging shall be taken into consideration.

#### **4.2.3.6 DC regulation**

Static regulation is to be (+/-) 0.5% RMS voltage from 0 to 100 % full load having a +10 % / - 12% input voltage variation (as per NEMA PE-5) and +/- 5% frequency.

#### **4.2.3.7 Output current**

Charger shall be capable of providing 100 % of rated output current on a permanent basis.

#### **4.2.3.8 Ripple voltage**

Ripple is to be limited to 30mVrms for 48VDC systems, when connected to a resistive load (not to a battery). The battery charger must be able to operate without being connected to a battery.

### 4.2.3.9 Redundancy Design

#### 4.2.3.9.1 Dual charger, single battery system

Charging system shall have two identical chargers. Both chargers shall be of identical design and rating capable of parallel operation.

Forced current sharing must be provided with no common circuit or control wiring between chargers to prevent One Common Point Failure.

The chargers and battery sets shall be interconnected as shown in **fig. 3.9.1.1**

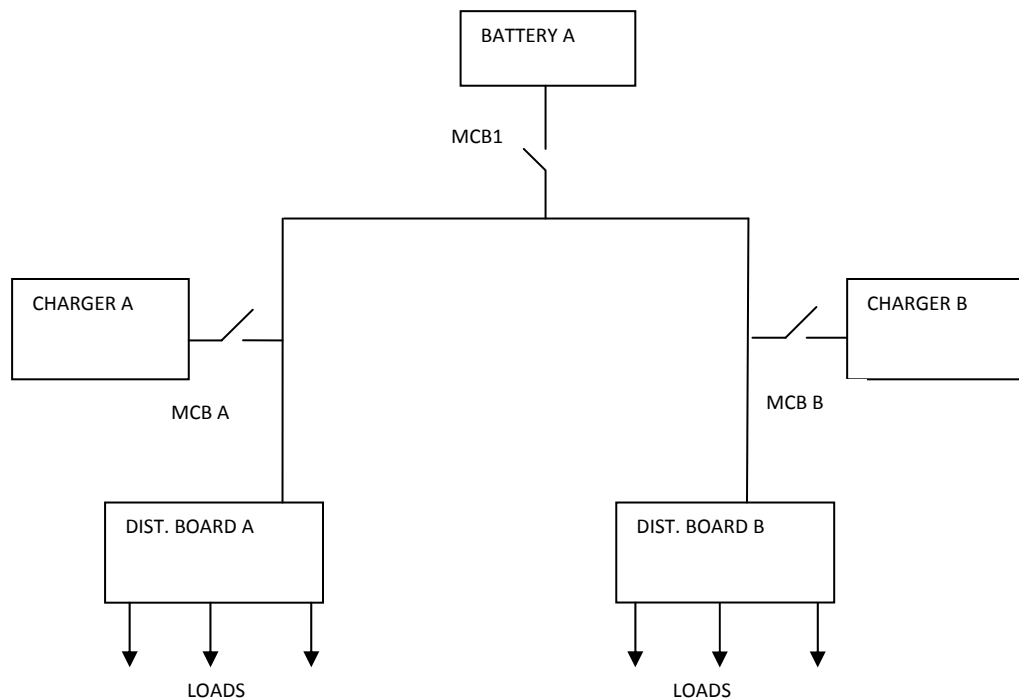

**Figure 4-1 Fig. 4.2.3.9.1:**

Normal operation shall be MCB A, MCB B, MCB1 closed.

In the event of any charger trip, both D.C.D.B shall be energized by the other charger. To offer operational redundancy, the charger shall meet the load requirements if one rectifier fails. Therefore, each Charger unit shall have N+1 rectifier units, where N is the number that meets the Load requirements. This shall be irrespective of loading calculations. The number of

rectifiers per charger shall be determined by the total loading per site as shown in the schedule of requirements and shall be rounded up to the nearest unit.

There shall be at least one spare rectifier slot for a two rectifier charger and minimum two spare slots for changers with more rectifier units. The spare slots shall be fully equipped.

- a) The battery bank shall be designed for full load standby as specified elsewhere in this specification.

#### 4.2.3.9.2 Dual Charger, Dual Battery System

Charging system shall have two identical chargers with specifications as indicated in 3.9.1

- a) Each charger unit shall be capable of supplying the initial charging requirements, boost charging the battery subsequent to an emergency discharge and supplying the maximum load whilst on float.
- b) The chargers and their respective battery sets shall be interconnected to ensure full redundancy as shown in **fig. 4.2.3.9.2:**

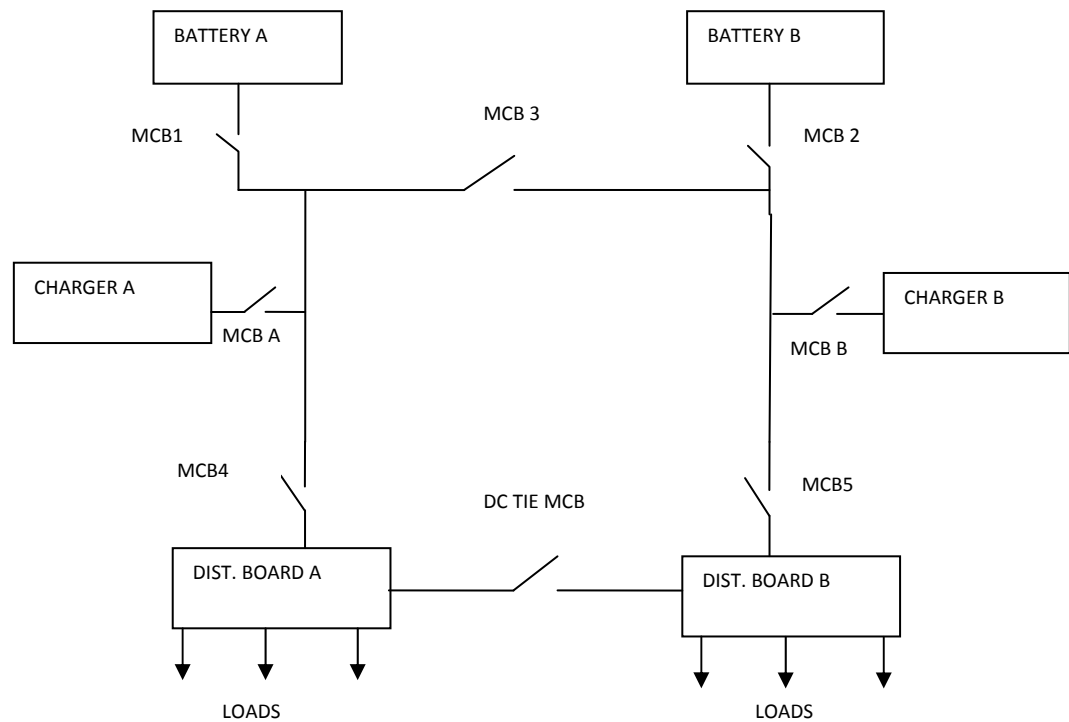

**Figure 4-2**

- c) The chargers shall be interlocked so that only one battery may be boost charged at any time.
- d) Each charger shall connect to its own DC distribution Board with capacity to connect all loads and spares as specified elsewhere in this specification.
- e) The distribution boards shall be interconnected via a DC tie MCB.
- f) Each charger shall have its output protected by an MCB, (MCB A & MCB B) which shall trip in event of a major internal fault in the charger.
- g) The normal operation shall be MCBA, MCB B, MCB 1, MCB 2, MCB4, MCB5 shall be closed and MCB3, DC tie MCB shall be open. In event of charger trip, the DC tie MCB shall close automatically, followed by paralleling of the battery banks, (MCB3 close) without load interruption. This operation shall have a manual bypass. The tripping of MCB3 shall generate a critical alarm in the controller and also pick a dry alarm contact.
- h) In event of a fault in a battery bank, its MCB (MCB1 or MCB2) shall trip and MCB3 shall close. Each trip shall generate a battery faulty alarm and pick a dry alarm contact.

The chargers shall have Event controlled charge such that the event in cl 4.6.2, i shall set a charge mode to accommodate two battery banks.

- i) Each charger shall be capable to charge and monitor the two battery sets in parallel.
- j) Rectifier spare capacity shall be as spelled in cl. 4.9.1 (a) for each charger.
- k) Each battery bank shall be designed for full load standby as specified elsewhere in this specification.
- l) The supplier may submit design proposals, showing how to achieve the required redundancy for both systems.

#### **4.2.3.10 Operating tolerances**

Operating temperature -0°C to +50°C, indoors.

Relative humidity 95% without condensation

Operating altitude to 3300 feet with no de-rating

Input A.C supply shall be 230V, 50Hz for single phase and 415V, 50 Hz for three phase.

#### **4.2.4 BATTERY**

##### **4.2.4.1 Batteries**

One set of continuous duty battery with minimum AH capacity as specified in the bill of quantities for each site, shall be supplied.

Batteries shall be of the Nickel-Cadmium, Free maintenance and suitable for low rate discharge applications.

A ternary alkaline electrolyte shall be used to increase performance at high temperatures.

The battery shall be designed using cells encased in a common battery module, and connected in series with intercell connectors. The cells shall be constructed into battery blocks using stainless steel cradle and fitted with lifting handle to facilitate easy handling and installation.

Terminals shall also be provided to connect to the adjacent modules in series to achieve a 48VDC string. One 48VDC string shall be designed for 100Ah capacity. Several 48VDC strings may be connected in parallel to achieve the required Ah capacity. Each string shall have a battery disconnect circuit breaker.

The + ve electrodes shall be made by encapsulating/impregnating active material on nickel-plated steel grid/perforated strips, which shall form micro porous cavities exposed to the electrolyte, thus increasing conductivity in order to ensure that the battery is able to perform reliably over its life.

Similarly, the –ve plate shall be made by encapsulating/impregnating active material on both side of perforated nickel plated steel plates, to ensure mechanical strength throughout the lifespan of the battery.

+ve and –ve electrodes shall be separated by micro porous separators, which shall maintain mechanical separation between electrodes, stop migration of the active material, allow electrolyte permeability and retention over its useful life.

The battery shall have an overall charge efficiency greater than 80%.

The batteries shall have high internal gas recombination efficiency and low gas emissions exceeding the requirements of IEC 62259, such as to eliminate watering during the entire life span of the battery. Minimum recombination efficiency shall be 100% at normal operating conditions.

The battery shall have a built in, low pressure venting system of self-resealing type with minimum venting pressure of 150PSI. The vent shall have a flame arresting feature.

Construction of cells shall ensure adequate heat dissipation.

- a) Batteries shall comply with the performance requirements of IEC 60623, GR-3020, NEBS Level III, and the environment requirements of GR-3108.

The battery packs shall have a thermal cut-off inside that feeds back to the charger telling it to stop the charging once the battery has heated up and a voltage sensing circuit.

The cell containers shall be of robust, impact resistant construction in translucent material permitting visual inspection of electrolyte and shall be having built-in pressure release valves. The material shall be flame retardant according to UL 94 VO.

Nickel plated copper intercell connectors shall be used for connecting up adjacent cells and rows. Bolts, nuts and washers shall be nickel-plated steel/stainless steel.

All terminals and cell inter-connectors shall be fully insulated or have insulation shrouds. Terminals and intercell connectors shall be protected and kept clean by a 'dead top' in line to EN 50272-2 (safety) with IP2 level.

Separate terminals shall be provided on the end cell for connecting load through

D.C.D.B. and for connecting charger leads. All terminals shall be of suitably sized nickel-plated steel. Suitable nickel-plated copper lugs shall be provided by the supplier for use of the purchaser for connecting up the load wiring. All connectors and leads shall be suitable for carrying 30-minute discharge current continuously and rated for short circuit duty of 4kA for 01 second.

The cell containers shall be marked with maximum and minimum electrolyte levels.

Further, the battery bank terminal cables shall be routed via a double pole wall mounted fuse-switch, and the fuse shall be selected so as to discriminate for a fault on the d.c. bus. For a case where the battery shares a cabinet with the charger, the same shall be provided on the cabinet.

Batteries shall be clearly identified by permanent numbering. The following information shall be provided on a permanent identification plate with each battery block:

- (i) Manufacturer's reference No. & Code
- (ii) Year and month of manufacture
- (iii) Voltage and nominal capacity at 8 hr. discharge rate.

The manufacturer shall supply a copy of the instruction manual for commissioning & initial treatment of the battery and maintenance during service with every battery bank supplied.

#### **4.2.4.2 Operating Tolerances**

- Operating temperature: -20 deg. C to +50 deg. C
- Relative humidity 95% without condensation

#### **4.2.4.3 Battery Fuses**

The rating of the battery fuses shall be at least twice the rating of the largest d.c. miniature circuit breaker used in the distribution circuits and shall be so sized that they do not fail through fatigue

brought on by normal charge/discharge conditions. The battery shall be protected by fuses inserted in the connections between the charger and load.

#### **4.2.4.4 Battery Earthing**

The batteries shall operate earthed on the positive electrode. Means shall be provided to detect low insulation resistance of all the wiring connected to the battery by an appropriate earth fault detection circuit and to give an earth fault alarm.

The earth fault relay shall be equipped with a minimum of three normally open contacts for local indication and remote alarm circuits.

#### **4.2.4.5 Battery Accessories**

Each battery set shall be provided with the following appropriate accessories:-

- -One - cell testing equipment including voltmeter and thermometer.
- -One –AC/DC current clamp meter of  $\pm 0.025\text{mA}$  accuracy.
- -Two - cell bridging connector.
- -One - instruction card and record chart.

#### **4.2.4.6 Racks**

Suitable corrosion resistant battery racks and cable supports shall be provided ensuring that:

Metallic racks shall be properly earthed.

A minimum floor area is taken up and a ground clearance of 300 mm from the floor is provided.

Racks shall be made of alkali resistant powder coated steel or stainless steel or FRP to ensure corrosion resistance.

- a) Each battery module is readily accessible and can be removed from its position without having to remove or shift adjacent modules.
- b) The supplier shall furnish complete rack drawings showing battery arrangement, dimensions in respect to available space.



#### **4.2.4.6 Safe disposal of unserviceable batteries**

The bidder shall have facilities for proper treatment & disposal of used/unserviceable batteries that are bought back from the users, in line with the environmental protection rules & regulations of the country.

#### **4.2.5 D.C. CONTROL AND DISTRIBUTION BOARD**

The DC Control and distribution board shall be equipped with MCBs.

The equipment shall be capable of carrying, making and breaking the maximum possible fault current and details of the make-up of this shall be provided. Curves of battery current plotted against time under short circuit conditions shall be supplied.

Outgoing distribution cables shall be connected directly to the relevant MCB.

Cabling and wiring terminations shall be shrouded to avoid accidental short circuit or earthing of the battery. PVC insulation shall be used for fuse wiring connections.

Suitable means shall be provided such that, when the charger is operating in float charge mode and when switching to boost charge mode, the voltage at the outgoing distribution terminals shall be automatically limited to within the tolerances as specified elsewhere in this Section. This shall be achieved by the insertion of voltage dropping diodes into the input circuit and the diodes shall have a rating of at least twice the board's standing load. A minimum of three diode strings (stages) shall be provided which shall be inserted into the input circuit of DCDB in stages to provide the range of voltage control in DCDB within limits as specified elsewhere in this section. It is preferred that during float mode the diode assembly shall not be included in the circuitry. An alternative method may be used subject to approval by Kenya Power.

Suitable alarm relays shall be provided to monitor at the distribution board both high and low battery voltages to pre-set values. The relays shall be fitted with variable time delays adjustable between 0-30 seconds. The relays shall indicate the fault condition locally and shall have two sets of voltage free contacts for indication to SCADA.

#### **4.2.5.1 D.C. Distribution**

The panel(s) shall house all distribution necessary for the station d.c. circuits; they shall at least be of protection class IP41 with self-cooling, Bottom plate of the D.C.D.B. shall be of detachable type for entry of outgoing feeder cables.

Minimum three spare breakers (10A, 16A, 32A), fully equipped, shall be provided.

The d.c. panels shall have an alarm table aux (sub-panel) for alarm indications such as:

- Lamp test
- supply in feeds off
- D.C. trip (one for all breakers)

In addition, provision for having one general d.c. alarm connected to the alarm panel in the station control room shall be provided.

D.C. ammeters and voltmeters shall be provided.

#### **4.2.6 METERING AND MONITORING SYSTEM**

##### **4.2.6.1 4.2.6.1 Local Access**

The controller shall have at least 5 configurable LEDs

The controller shall have an interactive LCD display and protected by a password **All** voltage and current readings as well as all alarms and controls status shall be accessed and displayed on the LCD. In case of AC Fail, LCD display must be operational.

A keypad to program the controller

A buzzer to sound in case of an alarm.

Real time Read / Write communication port shall be supplied to access all setup and status parameters through:

- Web page via local or dynamic IP address
- -Fully licensed proprietary software

- The following shall be available on the controller module, in English:
- AC on Green LED;
- Common alarm Red LED;
- Simultaneous display of rectifier output current and voltage.
- Display of charging mode and alarm status.
- Display of sequenced event log on LCD: For easier troubleshooting due to an event.
- Battery Charge/discharge ammeter/ ampere hour meter.
- 0-134 months, in one hour increments, automatic/manual equalize timer with elapsed and remaining equalize time indication

#### **4.2.6.2 Remote Access**

- It shall be possible to access the charger remotely to read/write configuration parameters through:
  - SNMP
  - Telnet
  - Modbus TCP/IP
  - Dial up Modem
- A common alarm form C contact must be provided as a backup.

#### **4.2.6.3 Monitoring System**

- Each alarm must be displayed on an LCD display. Memory chip must keep the last 350 events with a date and time stamp. The log must be accessible for download through
  - HyperTerminal.
- Minimum alarm available for activation shall be:
  - Rectifier failure
  - AC fail
  - High DC volts
  - Low DC volts
  - Positive ground fault
  - Negative ground fault

- End of discharge
- High volts cyclic shutdown
- Equalization on
- High ripple
- Low & High Frequency alarm and shutdown and automatic restart
- High & Low charger temperature alarm and cyclic shutdown
- Rectifier high current
- Rectifier High volt
- Rectifier low volt
- SNMP traps for alarm remote monitoring
- Integrated GSM interface for configurable SMS alerts for alarms.
- At least six configurable dry contacts
- The following alarms are mandatory to be configured on the dry contacts individually or as a group:
  - Battery fuse failure
  - Battery circuit faulty
  - Low DC volts
  - High DC volts
  - Earth fault –ve.
  - Mains Failure
  - Charger trip/ output low
  - Any critical alarm
- Charger shall be also equipped with:
  - Configurable alarm classification
  - DC bus voltage measuring device capable of converting the DC bus voltage measuring range into DC mA range. The DC bus voltage range shall be 0-75V, and the DC mA range shall be 0-20mA.
  - Battery imbalance alarm
  - Battery continuity tester

- Temperature compensation based on battery temperature

#### **4.2.6.4 PROTECTION**

AC and DC surge suppression as per ANSI/IEEE 37.90.1 (SWC)

AC Lightning arrester as per ANSI/IEEE C62.11

AC input circuit breaker c/w with a high DC volts shunt trip and Open circuit form C alarm contact.

Two (2)-pole DC output circuit breaker.

Two (2)-pole battery maintenance disconnect switch.

High DC voltage shutdown/disconnect

Low DC voltage disconnect for batteries.

All circuit breakers are to be coordinated with the AC input, battery and rectifier short circuit capabilities. (Specify the KA rating of each)

#### **4.2.7 ENCLOSURE**

All equipment, in cubicles of free type standing where applicable, shall either be housed in individual sheet steel cubicles or alternatively all of the equipment shall be housed in one single cubicle segregated into compartments by sheet steel separators.

For dual chargers, each charger shall be housed in a separate enclosure.

Individual cubicles shall have a hinged front cover with locking facilities, giving full access to all components and cable connections.

All controls and relays shall be placed inside the cubicles.

The enclosure is to be ventilated and protected to class IP42.

The equipment shall satisfy the requirements of corrosion protection as specified.

Where ventilation openings are provided these shall be fitted with drip-proof louvers and fine mesh wire or perforated screens to exclude small insects and vermin.

A gland plate shall be provided sufficient for all incoming and outgoing cables including spare capacity, and shall be mounted not less than 200 mm from the base of the cubicle, except where there is a cable trench.

Where all the battery charger and distribution equipment is housed in a common cubicle, particular attention shall be made with regard to the routing of cables from the base of the cubicle to the respective compartments taking account of ease of installation, segregation from the battery charger compartment etc.

The complete battery, charger and distribution units shall be designed to enable a each to be removed and replaced with ease and without disturbance to the remainder of the equipment and wiring. Facilities shall be provided for testing batteries and chargers without load disconnection.

The minimum thickness of sheet steel used in the construction of cubicles, compartments etc. shall be 2.5 mm throughout. All meters and indication lamps shall be flush mounted on the front of the cubicle and their function clearly indicated with screw-on labels

The paint colour is to be ANSI 61 Gray Cable entry is to be from either the cabinet top or bottom

When applicable, seismic rating must be specified

#### **4.2.8 MANUALS, DRAWINGS AND MAINTENANCE SOFTWARE**

As part of tender offer, the tenderer shall submit proposed design drawings showing:

- Component arrangement in cabinets, racks
- Block diagram showing wiring connections and operation principle.

After the award of the tender, the DC Battery Charger and battery shall come complete with installation, operation and maintenance manuals. As built drawings, individual test report and complete bill of materials shall also be provided.

The chargers shall be delivered with Maintenance software's, if any, with fully paid licences.

#### **4.2.9 SPARE PARTS**

The supplier shall recommend two (2) years operation spares as indicated in schedule 16.2. In addition, the supplier shall supply and deliver to Kenya Power stores the following spare parts:

Four No. Spares for each common board in the charger.

#### **4.2.10 WARRANTY**

Battery charging system minimum acceptable warranty shall be 12 months from commissioning.

Minimum acceptable warranty for batteries shall be 12 months from commissioning.

#### **4.2.11 TRAINING**

The supplier shall offer onsite technical training for operation and maintenance of batteries and chargers. The training shall be for at least four persons.

#### **4.2.12 TESTS**

##### **4.2.12.1 Tests At Factory**

###### **4.2.12.1.1 Battery**

The batteries shall be tested for type, capacity, functionality, performance and routine tests in line with IEC 60623 & IEC: 62259 (latest versions) at the manufacturer premises prior to shipping, and shall be witnessed by two Kenya Power representatives. Type test reports for tests carried out not earlier than 03 years from bid opening date from accredited labs in accordance to cl. 3.14.4, shall be acceptable.

Tests shall be done to determine:

-The charging cycle

-8hr discharge cycle

-Ah efficiency

Temperature measurements shall be made during charging and discharge tests to determine the cell behavior.

Test reports showing water usage on float charge at maximum operating temperature of 50 deg. C, conducted over a two year period shall be submitted, as a proof of maintenance free operation over the service life of the battery.

Note: In case Type tests are repeated, life cycle test may not be insisted upon Ni-Cd battery of the specific ratings to be ordered, as this test takes a long time (2-3 years). However, satisfactory evidence shall be furnished for having made this test on cell of any other Ah capacity of the same design.

#### **4.2.12.1.2 Charger and D.C.DB**

Type test reports for tests performed on, charger (IEC 60146) and D.C.D.B (IEC 60439) as per relevant IEC where applicable, shall be submitted. The tests shall include and not limited to:

Complete physical examination.

Temperature rise test at full load (at highest voltage & highest current).

Insulation resistance test.

High voltage (power frequency) test on power and control circuits except low voltage electronic circuits.

Ripple content test at

- -No load
- -Half load
- -Full load

Automatic voltage regulator operation test at specified A.C. supply variations at:

- -No load



- -Half load
- -Full load

Load limiter operation test

Efficiency and power factor measurement.

Cooling characteristics for Rectifier and transformer at full load.

#### **4.2.12.1.3 Environmental Tests**

Steady state performance tests shall be carried out before and after each of the following tests.

Soak Test

All electronic modules shall be subjected to continuous operation for a minimum period of 72 hours. During last 48 hours, the ambient

Temperature shall be maintained at 50 deg. C. The 48 hour test period shall be divided into four equal 12 hour segments. The input voltage during each 12 hours shall be nominal voltage for 11 hours followed by 110% of nominal voltage for 30 minutes, followed by 90% of nominal voltage for 30 minutes. The manufacturer shall submit the record of carrying out this test to the Kenya Power engineer at the time of inspection.

Degree of protection test (IP-42).

If type tests are carried out against the contract, minimum 15 days' notice shall be given by the contractor. The contractor shall obtain the Kenya Power approval for the type test procedure before conducting the type test. The type test procedure shall clearly specify the test set-up, instruments to be used, procedure, acceptance norms, recording of different parameters, interval of recording, precautions to be taken etc. for the type tests to be carried out.

If evidence of successfully carrying out the above tests is not available, the above tests shall be carried out on one unit in presence of Kenya Power without any extra cost.

Battery Charger - Type tests according to IEC 146

DC Switchboard - Type tests according to IEC 439.

#### **4.2.12.1.4 Routine Tests**

Routine tests shall be carried out in accordance with IEC on all battery banks, chargers and D.C.D.B shall include the following tests, but not necessarily be limited to them:

Battery - The Contractor shall demonstrate that the battery will perform the duties specified in accordance with this specification.

Battery Charger - Routine tests according to IEC 146

DC Switchboard - Routine tests according to IEC 439.

In addition, the following routine tests shall be carried out on all Battery Chargers:

Complete physical examination.

Short circuit test at full load and at no load for sustained short circuit of 10 sec (min. shall be carried out). The charger shall not trip, no fuse shall blow and charger current shall be limited to 150% of the rated current.

Insulation resistance test.

High voltage (power frequency) test.

Ripple content test at

- -No load
- -Half load
- -Full load

Automatic voltage regulator operation test at specified A.C. supply variations at

- -No load
- -Half load
- -Full load

Load limiter operation test

Checking of proper operation of annunciation system including a burn in tests.

Dynamic response test Overshoot/Undershoot in output voltage of the charger as a result of sudden change in load from 100% to 20 % and 20% to 100% shall be measured with the Batteries connected/disconnected. Output voltage of the Charger connected with Battery shall be within 90 % to 110 % of the voltage setting in above conditions and shall return to, and remain, within the limits specified in clause 4.3 in less than 2 seconds (as applicable).

Soak Test (as per cl 12.3, i) - shall be carried out on all electrical modules/ panels as routine test.

The Contractor shall furnish for inspection, the type and routine tests certificates for Chokes and transformer whenever required by the Employer.

#### **4.2.12.2 Tests At Site**

All tests shall be carried out at site in accordance with IEC on all battery banks, chargers, inverter and DCDB. Any test found necessary by Kenya Power during commissioning, the same shall be carried out without any contractual implication.

#### **4.2.13 APPLICABLE STANDARDS**

*The design, installation and testing of 48 VDC Chargers, Batteries and DC control and distribution Boards shall comply to these standards or equivalent.*

- UL1012: Power Units Other Than Class 2
- CSA-C22.2 No.107.1: General Use power Supplies
- NEMA PE 5: Utility Type Battery Charger
- IEEE 946: IEEE Recommended Practice for the Design of DC Auxiliary Power Systems for Generating Stations
- EN61000-4-4: IEC Electrical Fast Transient/Burst
- ANSI/IEEE C37.90.1: Surge withstand capability NEMA PE5
- IEC 60623: Vented nickel cadmium rechargeable single cells
- IEC 62259: Secondary cells and batteries containing alkaline or other non-acid

- electrolytes Nickel-cadmium prismatic secondary single cells with partial
- gas recombination
- BS 5634: Testing potassium hydroxide used in alkaline cells.
- BS 381C: Specification for colours for identification coding and special purposes.
- BS 4417: Specification for semiconductor rectifier equipment's.
- IEC 146: Semiconductor convertors.
- BS 88: Cartridge fuses for voltages up to and including 1000V AC and 500V
- DC

#### 4.2.14 SCHEDULES

##### 4.2.14.1 Guaranteed Technical Specifications

**Tenderer name:**

**Signature:**

**Table 4-1 Guaranteed Technical Specifications**

Item No.	Description	Unit	Kenya Power Requirements	Tendered offer
A	Batteries			
1	General			
	Manufacturer			
	Country of manufacture			
	Standard	.....	IEC 60623, IEC 62259	
	Type of battery	.....	Ni-cd	
	Rated system DC Voltage	V	48	
	System DC Voltage range	V	41.8-57.2	
2	Housing			
	Housing dimensions	mm		

	a)Height b)Width c)Length			
	Weight per housing	kg		
	Housing Material(plastic/other )			
	Overall dimension of battery bank  a)Height  b)Width  c)Length	mm		
	Approximate weight of battery set	kgs		
	Battery layout drawing furnished		yes	
3	Cell details			
	Exterior color		Translucent/transparent	
	Electrolyte level visible	Yes/no	Yes	
	Vent provided	Yes/no	yes	
	Type of vent		Low Pressure	
	Vent Release pressure	psi	150-200	
	Type of positive plate		Sintered Matrix	

	Type of negative plate		Plastic Bonded	
	No. of positive plates per cell			
	No. of cells per Battery	No.	38-40	
	Type, material, thickness of separator			
	Overall dimension of each Battery block (Max)			
	a)Height	mm	260	
	b)Width		110	
	c)Length		500	
	Material of the container		flame retardant polypropylene	
	Spill proof	Yes/no	yes	
	Maintenance free type	Yes/no	yes	
	Nominal Cell Voltage	V	1.2	
	Internal resistance of the cell			
	Application		Indoor,	

4	Cells arrangement			
	Cells arrangement in battery	Tiers/crates		
	Positive terminal marking	Yes/no	Yes	
	Negative terminal marked	Yes/no	Yes	
	Name/type labling on cell	Yes/no	Yes	
5	Electrolyte			
	Type of electrolyte	Ternary Alkaline		
	Volume of electrolyte per cell	ml		
	Reserve electrolyte per cel	ml	0.6ml/Ah	
	Density of electrolyte at 25deg. C			
	a)for first fill	g/ml		
	b)at full charge	g/ml		
	c)At end of 8hr discharge	g/ml		
	Standard conforms to		IEC 60993	
6	Design			
	Ah Capacity for each	List	yes	



	site			
	Energy Density	Wh/L	100	
	Ah efficiency	%(min)	80	
	Watt hour efficiency	%(min)		
	Self discharge at 35 deg. C	%/week		
	Float charge Voltage/cell	Volts/cell	1.38-1.45	
	Float/trickle charge current at 1.43V	mA/AH	0.3-0.49	
	Boost charge voltage (max.)	V/cell	1.55	
	Boost charge current (max.)	A		
	End of 8 hour discharge voltage	V/cell	1.1	
	Operating temperature (min)	Deg. C	-20	
	Operating temperature (nominal)	Deg. C	35	
	Operating temperature (max.)	Deg. C	50	
	Life time (on float at 50 deg. C)	Yrs (min)	>15	
	Expected service life at 35 deg. C	Yrs (Min)	20	

	Water usage on float at 35 deg. C	Cc/Ah/month/cel 1		
	Ventilation requirement at float	Ltrs/hr		
	Ventilation requirement at boost	Ltrs/hr		
	Total cells in battery bank	No.		
	Type of Racks		Stainless/ epoxy bonded Steel	
	Rack drawing submitted	Yes/no	yes	
	Recycling facilities for unserviceable batteries available	Yes/no	Yes	
B	Battery charger			
1	General			
	Manufacturer			
	Country of manufacturer			
	Type			
	Standard			
	Thyristor controlled charger	Yes/no	Yes	

	Switched mode charger	Yes/no	Yes	
	Charger efficiency	%	>87	
2	Charger Cubicle Details			
	size	mm		
	Degree of protection		IP42	
	Air vent filters	Yes/no	Yes	
	Housing material			
	Wall thickness	Mm (min)	2.5	
	Door opening angle	Deg.	>150	
	Type of paint		Hot Bonded Epoxy	
	Color of paint		ANSI 61 Gray	
	Weight of charger	Kgs		
	Internal cooling method	Fan/self/other	Fan, self	
3	Design Details			
a)	Input A.C supply			
	Input Voltage	V	150-250	
	Input supply frequency	Hz	47-55	

	Input A.C control by MCCB	Yes/no	yes	
	Input isolation transformer	Hz		
	Transformer taps available	Yes/no		
	Rated a.c input power	kva		
	Heat loss at rated output	W		
	Operating temperature, min	Deg. C	0	
	Operating temperature, max	Deg. C	50	
	Operating Humidity, max	%	95	
b)	DC Output			
	Rated d.c output current for each site	list	yes	
	Rated output voltage range	VDC	47-59	
	Output voltage static regulation	%	-+5	
	Voltage dynamic regulation(step)	%		
	Output voltage ripple w/o battery	mVrms	30	

c)	Protection and features			
	Current limit feature	Yes/no	Yes	
	Output short circuit Proof	Yes/no	Yes	
	Overvoltage alarm/protection	Yes/no	yes	
	Under voltage alarm	Yes/no	yes	
	Battery over discharge protection	Yes/no	yes	
	AC/DC Surge suppression	Yes/no	yes	
	Full charge detection		Timer, Change in V & change in T	
	Event controlled charge	Yes/no	yes	
	Automatic battery testing(capacity, real load, time based, constant current)	Yes/no	yes	
	Soft start feature	Yes/no	yes	
	D.C earth fault detector	Yes/no	yes	
	Rectifier Module I/O isolation	Yes/no	yes	

	Output current indication	Yes/no	yes	
	String current supervision	Yes/no	yes	
	Redundancy and power capacity supervision	Yes/no	yes	
	Static AH meter	Yes/no	yes	
	Auto switchover to boost mode	Yes/no	yes	
	Auto revert to float mode	Yes/no	yes	
	Manual mode selection	Yes/no	yes	
	Adjustment for float voltage	Yes/no	yes	
	Float voltage setting range	V		
	Adjustment for boost voltage	Yes/no	yes	
	Boost voltage setting range	V		
	Adjustment for current limit	Yes/no	yes	
	Current limit setting range	+/-%		
	Adjustment for over voltage	Yes/no	yes	

	Overvoltage setting range	+/-%		
	Adjustment for under voltage	Yes/no	yes	
	Under voltage setting range	+/-%		
	Adjustment for d.c. earth fault	Yes/no	yes	
	Earth fault setting range	mA		
	Automatic Load share between modules	Yes/no	yes	
	Load share setting range	+/-%	<10	
	Voltage monitoring unit built in	Yes/no	yes	
	Interlock to allow only on charger on boost charge - built in	Yes/no	yes	
	Current rating of power contactors used	A		
d)	Redundancy			

	Design proposal submitted	Yes/no	yes	
	Random operation	Yes/no	yes	
	N+1 rectifier units	Yes/no	yes	
	Spare rectifier slots	Yes/no	yes	
e)	Alarm and Indication Lamps			
	Input a.c 'ON' LED	Yes/no	yes	
	Output DC ammeter	Yes/no	yes	
	Output DC voltmeter	Yes/no	yes	
	Load bus voltmeter	Yes/no	yes	
	Comprehensive alarm monitoring	Yes/no	yes	
	Comprehensive alarm indications	Yes/no	yes	
	Alarm contact available including SCADA	Yes/no	yes	
	Discharged battery recharge time	Hr	12	
	Battery monitoring included	Yes/no	yes	
	GSM SMS alert	Yes/no	yes	
	SNMP traps	Yes/no	yes	



	MODBUS TCP/IP capable	Yes/no	yes	
4	Blocking diodes			
	Manufacturer			
	Type/cat. No			
	Reference standard			
	Current rating			
	Peak inverse voltage			
C	Distribution Board			
1	General			
	Manufacturer			
	Type of construction			
	Degree of protection			
2	Busbars			
	Material		copper	

	Minimum clearance of busbar and connections :  -Between phases  -Phase to earth			
	Maximum current rating	amps		
	Dimensions	mm		
	Short time current rating	amps		
3	Boost charge contactors			
	Manufacturer			
	Maximum current rating	amps		
	Coil ratings	W		
	Method of interlocking			
	Alarm relays			
	Manufacturer			
	Type and reference			

	Power consumption			
	Quiescent	W		
	Operated	E		
5	Number and rating of distribution  Circuits			
6	Overall dimensions	mm		
7	Total weight	kg		

\*NOTES:

Guaranteed Technical Particulars should be typed. Ticking in the Supplier's offer box, or simply stating "YES" or "COMPLIED" will not be accepted.

#### **4.2.14.2 Recommended Spare Parts**

The Tenderer shall enter in this schedule the recommended spares and its prices which he recommends for 3 years operation with individual quantities and prices

Kenya Power may order all or any of the spares so recommended at his discretion.

The prices for spare parts shall not be included in the Tender Price.

**Table 4-2List of 48V Battery Chargers**

	Station	Battery Ah-12Hr	Charger output Rating (Amps)	Dual/Single battery system	Dual/Single Charger system	D.C.D.B
No.						
	<b>LOT1</b>					
	<b>Nairobi</b>					
1	Airport 66/11	200	50	Single	Single	Single
2	Industrial 66/11	200	50	Single	Single	Single
3	Limuru 66/11	200	50	Single	Single	Single
4	Machako 66/11	200	50	Single	Single	Single
5	Mombasa Rd 66/11	200	50	Single	Single	Single
6	Muthurwa 66/11	200	50	Single	Single	Single
7	Nyaga 66/11	200	50	Single	Single	Single
8	Steel Billets 66/11	200	50	Single	Single	Single
9	Kikuyu 66/11	200	50	Single	Single	Single
10	EPZ 66/11	200	50	Single	Single	Single
	<b>Mt. Kenya</b>					
11	Karatina 33/11	200	50	Single	Single	Single
12	Kerugoya 33/11	200	50	Single	Single	Single
13	Embu 33/11	200	50	Single	Single	Single
14	Githambo 33/11	200	50	Single	Single	Single
15	Kiganjo 33/11	200	50	Single	Single	Single
16	Meru 33/11	200	50	Single	Single	Single
17	Othaya 33/11	200	50	Single	Single	Single
18	Nanyuki 33/11	200	50	Single	Single	Single
19	Ndarugu 33/11	200	50	Single	Single	Single
	<b>LOT2</b>					
	<b>Coast</b>					
1	Kanamai 33/11 kV	200	50	single	Single	Single
2	Mwambungo 33/11 kV	200	50	single	Single	Single
3	Watamu 33/11 kV	200	50	single	Single	Single
4	Msambweni 33/11kV	200	50	single	Single	Single
5	Utange 33/11 kV	200	50	single	Single	Single
6	Kaloleni 33/11	200	50	single	Single	Single
7	Mbaraki 33/11 kV	200	50	single	Single	Single
8	Mwatate 33/11 kV	200	50	single	Single	Single

	<b>LOT3</b>					
	<b>West Kenya</b>					
1	Cheptulu 33/11	200	50	single	Single	Single
2	Kitale 33/11	200	50	single	Single	Single
3	Eldoret Depo 33/11	200	50	single	Single	Single
4	Eldoret Industrial 33/11	200	50	Single	Single	Single
5	Kapsabet 33/11	200	50	single	Single	Single
6	Kericho 33/11	200	50	single	Single	Single
7	Kisii 33/11	200	50	single	Single	Single
8	Kisian 33/11	200	50	single	Single	Single
9	Kisumu East 33/11	200	50	single	Single	Single
10	Sotik 33/11	200	50	single	Single	Single
11	Mogogosiek 33/11	200	50	single	Single	Single
12	Homabay 33/11	200	50	single	Single	Single
13	Obote Rd 33/11	200	50	single	Single	Single
14	Sotik 33/11	200	50	single	Single	Single
	<b>Central Rift</b>					
15	Marura 33/11	200	50	Single	Single	Single
16	Nyahururu 33/11	200	50	Single	Single	Single
17	Kihoto 33/11	200	50	Single	Single	Single
17	Njoro 33/11	200	50	Single	Single	Single
18	Rongai 33/11	200	50	Single	Single	Single
19	Elburgon 33/11	200	50	Single	Single	Single
20	Mwariki 33/11	200	50	Single	Single	Single
21	Nakuru Depo 33/11	200	50	Single	Single	Single
22	Gilgil 33/11	200	50	Single	Single	Single
23	Soilo 132/33	200	50	Single	Dual	Dual