

THE KENYA POWER AND LIGHTING CO. LTD.

SPECIFICATION

For

SINGLE PHASE POLE MOUNTED BOXES



NAME	NAME	DESIGNATION	SIGNATURE	DATE
Prepared by:	Peter Wanyonyi	1 st Assistant Engineer, Energy Management		2015:08:20
Checked by:	Eng. Margaret Kanini	Ag. Manager, Energy Management		2015:08:20
Approved by:	Joshua Mutua	General Manager, Customer Service		2015-8-24

REVISION RECORD

REVISION	DESCRIPTION OF REVISION	COMPILED BY	DATE	APPROVAL
0	3 rd Issue	Thomas Juma	2012-01-05	
0	4 th Issue	Peter Wanyonyi	August- 2015	



SPECIFICATION FOR POLE MOUNTED METERBOARDS

CONTENTS

0. Foreword
1. Scope
2. Service conditions Indian ocean
3. Enclosure protection
4. Ratings
5. Design philosophy
 - Preferred cable entry
 - Intended mode of operation
6. Construction
7. Materials
8. Paint work
9. Final colour
10. Safety and security
11. Particular requirements for pole mounted meter board
 - 11.1 Construction
 - 11.2 Materials
 - 11.3 Instructions and markings
12. Systematic diagram
 - 12.1 Details of pole mounted meter board.
 - 12.2 Position of Rail metal plate
 - 12.3 Overview of the complete meter board
 - 12.4 Position of cable gland
 - 12.5 Meter dimensions and configuration

POLE MOUNTED METERBOARD

0. FOREWORD

- 0.1 This standard specification has been prepared by the Energy Management department. It lays down specification for pole-mounted meter boards.
- 0.2 This specification is intended for guidance of manufacturers and contractors and shall form the basis of procurement and installation of meter boards for applications stated herein. It does not include provision of contract.

1. SCOPE

- 1.1 This specification is for the design and manufacture of meter boards and covers the following items:
 - (i) Discrete single-phase meter board, as detailed in Clause 11.

This specification covers meter boards for use for pole mounted meters supplied with 230V for single-phase meters.

1.2 References

- 1. BS381C: 1996 (2002) Specifications for colours for identification, coding and special purposes
- 2. BS 7079: Preparation of steel substrates before application of paints and related products and associated parts

2. SERVICE CONDITIONS

2.1 Operating conditions

2.1.1 The meter boards shall be suitable for safe operation in tropical climate with the following atmospheric conditions.

- (a) Altitude: 0 to 2200 metres above mean sea level.
- (b) Temperature: +45 C maximum and -1 C minimum, averaging +30 C
- (c) Humidity: 30% to 90%, with an average of 70%. (Note that Coastal areas have heavily polluting saline atmosphere and high humidity while inland areas have relatively clean air and low humidity.)
- (d) Pollution: Design pollution level to be taken as "Heavy". Corrosion protection should take this into account.

2.2 System characteristics:

The meter boards are intended to be operated on 230 V single phase system with protective multiple earthing (PME).

2.3 Operating height

The meter board is to be mounted vertically on the pole. It shall be therefore suitable for mounting and operation on outdoor where raindrops shall impinge upon it.

3. ENCLOSURE PROTECTION

- 3.1 The degree of protection of the enclosure shall be at least IP65 when the top cover is securely closed and sealed.

4. RATINGS

- 4.1 The meter board shall be rated at 100 A, 230V.

5. DESIGN PHILOSOPHY

The design of the meter boards are based on the following principles for optimum utilisation:

5.1 Din Rail metal plate

For safety and ease of use, the meter board shall be provided with one din rail metal plate to secure the meter and miniature circuit breaker (MCB). The dimensions of the rail metal plate are as shown in fig.1

5.2 Cable entry & exit gland

5.2.1 The meter board shall have two (2) cable entries and two (2) cable exit glands. Fig. 3 has the details.

5.2.2 The exit and the entry gland of the cable shall be all at the bottom of the meter board. Each cable gland shall have rubber seal sufficient to accommodate securely 16mm²-insulated cable.

5.3 Design and details of the meter boards.

5.3.1 The top cover shall be made of polycarbonate and easily opened by means of a hinge between it and the main meter board base; it shall be of insulation class II. Other parts shall be made of polycarbonates material, self-extinguishing and resistant to abnormal heat and fire up to 960 C, to be ascertained through glow test in accordance to IEC 60695-2-11 standard.

5.3.2 It shall have four sealing positions to prevent tampering and access by unauthorised persons.

5.3.3 It shall have a means of securing it firmly on the base using an Allen key. The Allen screws shall have holes (diameter 2mm) to accommodate the seal wire that will be used to seal the meter board.

5.3.4 A galvanized/electro plated steel mounting bracket shall be provided behind the meter board to assist in securing the meter board on the

pole. This mounting bracket should also have holes on the protruding parts to provide further provision to fasten the meter board tightly on the pole using 5/8" (diameter) X 11" (length) bolt."

- 5.3.5 The exit and entry gland of the cables shall be fitted with rubber seal, which enhance permanent weather-proof epoxy adhesive and able to accommodate 16mm² insulated copper wire.
- 5.3.6 Din rail metal plate shall be firmly positioned as shown on fig. 1 and shall able to firmly hold the meter bearing the weight of the cables.
- 5.3.7 It shall be possible to accommodate one (1) single phase meters in the meter board.
- 5.3.8 The complete design of the meter board shall be as shown in fig.3

6. CONSTRUCTION

- 6.1 Construction details and sizes shall be as detailed in the respective clauses.

7. MATERIAL

- 7.1 The material shall be polycarbonates material, self-extinguishing and resistant to abnormal heat and fire up to 960 C, to be ascertained through glow test in accordance to IEC 60695-2-11 standard. For other parts, it shall be as detailed in the respective clauses. The material should be ISO 75-2 certified and certificate for conformity should be availed.

8. METER BOX FINISH

- 8.1 The meter board shall have durable weather-resistant finish.

9. COLOUR

- 9.1 The final colour of the meter-board shall be *light aircraft grey* as per pigment No. 627 of BS 381C.

10. SAFETY AND SECURITY

The meter board shall be entirely made of an insulator. Four (4) holes of three (3) mm in diameter shall also be provided for wire sealing (see fig. 3).

11 Particular requirements for pole mounted meter board.

11.1 Construction

11.1.1 The meter board shall measure 300 mm (Height) x 240 mm (width) x 180 mm (Depth) top cover inclusive.

11.1.2 The holes for cable gland shall be 16mm² and shall be aligned as shown in fig.3.

11.1.3 The top cover shall be secured to the main body by means of stainless steel hinge and provide a comprehensive protection of the meter from any substantial drops of water.

11.1.4 It shall be possible to easily open the top cover to facilitate connection of the cables to the meter.

11.1.5 The meter boards shall be capable of accommodating 1 single phase prepayment split meters.

11.1.6 The meter boards shall come fitted with 1X4 way neutral copper terminal block as shown in figure 1.

11.1.7 Meter din rail metal plates shall be firmly secured as shown in fig. 1 below.

11.1.8 The dimension of the meter shall be as shown in fig. 5

11.2 Materials

The pole mounted meter board shall be made from the following materials:

11.2.1 Polycarbonate for use outdoor as detailed in section 7.

11.2.2 Top cover shall also be made of polycarbonate as detailed in section 7.

11.2.3 Cable gland shall have rubber seal to enhance permanent weather proof epoxy adhesive.

11.2.4 Meter din rail metal plates shall either be made of galvanized steel or electro plated metal.

11.2.5 Thickness, in millimetres, of the various components shall not be less than those indicated in the following table:

	Tolerance	Body	Top cover	Rail metal plate
Body and top cover	±0.1mm	3mm	3mm	1 ± 0.05 mm

11.3 Instructions and markings

11.3.1 The Top Cover shall be marked legibly and indelibly with the following information:

11.3.1.2 Name or trade mark of the manufacturer

11.3.1.3 Country of origin

11.3.1.4 HATARI! / DANGER! Warning of Electrical Hazard with standard symbol.

11.3.1.5 Property of Kenya Power.

11.4 Relevant technical details, schematic drawings, operational and service manuals shall be submitted to support the tender and shall be clearly marked to indicate the type/ model of the meter board being offered.

11.5 The Tenderer shall submit a clause-by-clause statement of compliance with these specifications in the format seen in Appendix A. In case of deviations the affected requirements shall be indicated.

11.6 Copies of test results of the meter board being offered certified by an international or the national certification body shall be provided. If test reports / certificate(s) is (are) from accredited certification laboratories (and not national or international body), then it (they) shall be accompanied with copies of certificates of accreditation from the national or an international certification body.

11.7 A sample of the meter board being offered shall be submitted together with the tender documents. This sample shall not be returned to the tenderer.

12. Systematic diagrams

12.1 Details of pole mounted meter board.

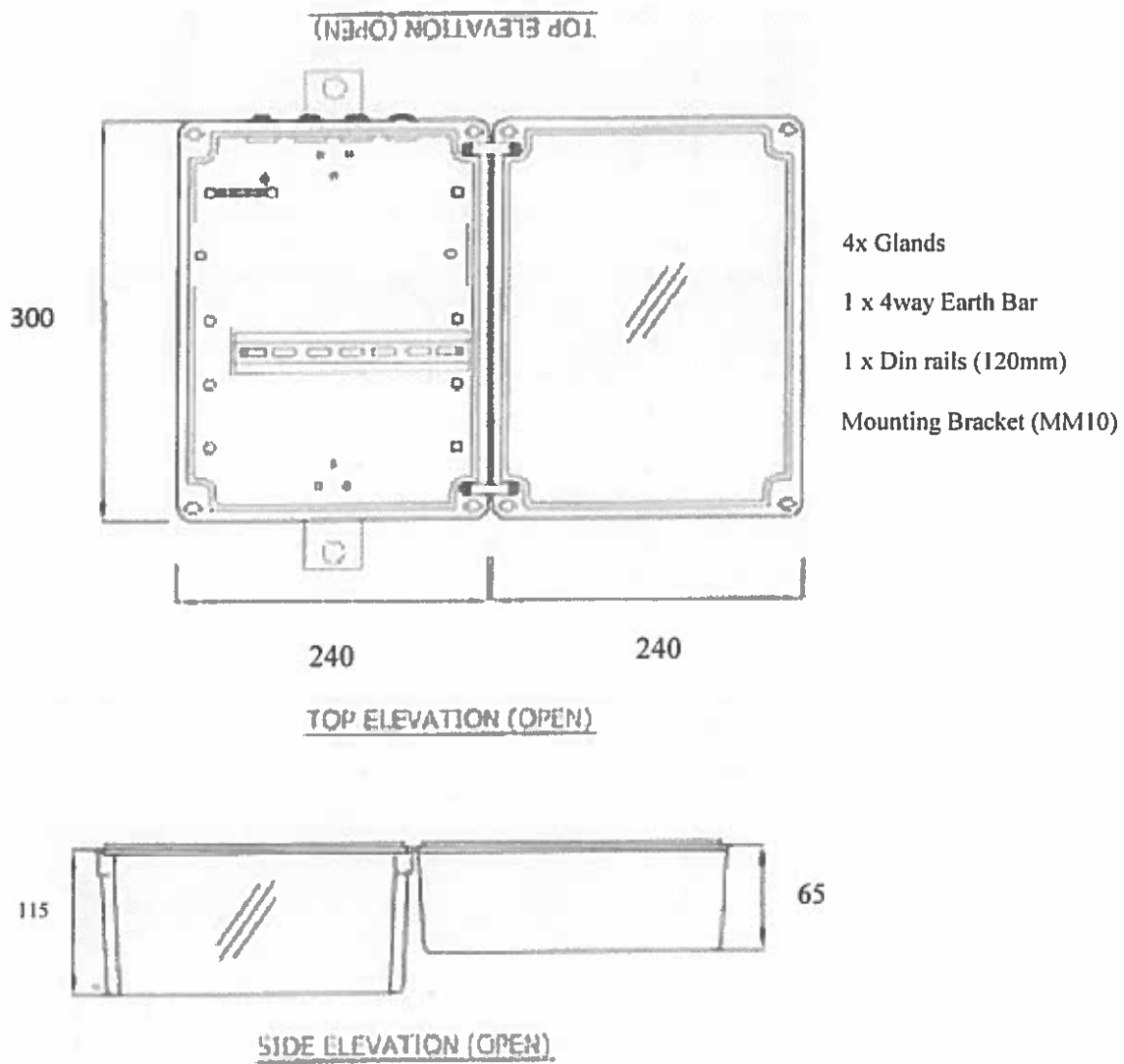

Fig. 1 Dimension of pole mounted Meter board

12.3 Overview of the complete meter board.

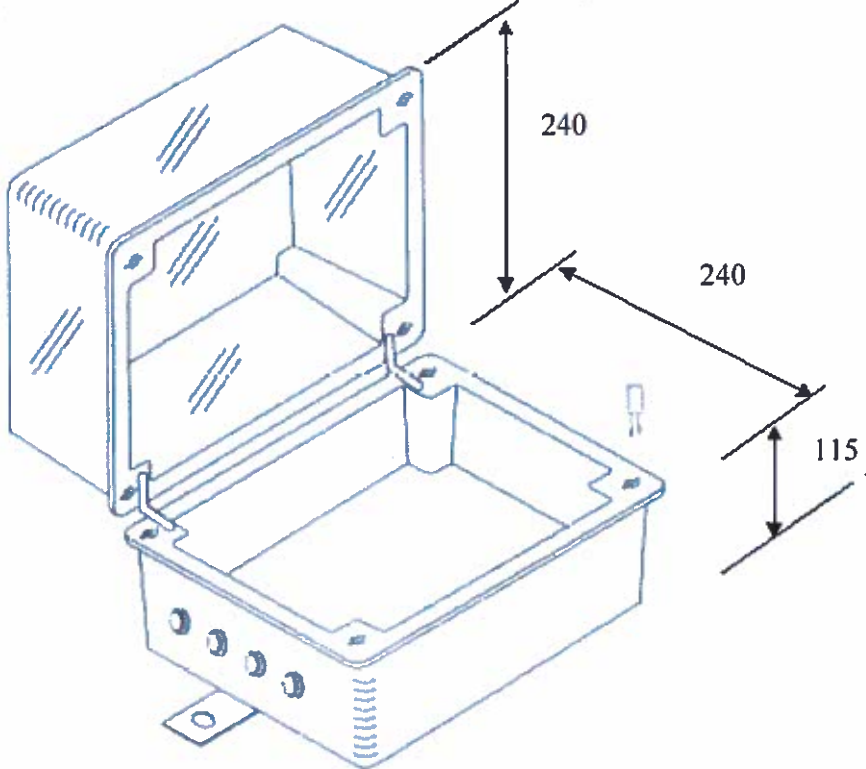

Fig. 3. Meter board general overview.

12.5 Meters dimensions and configuration.

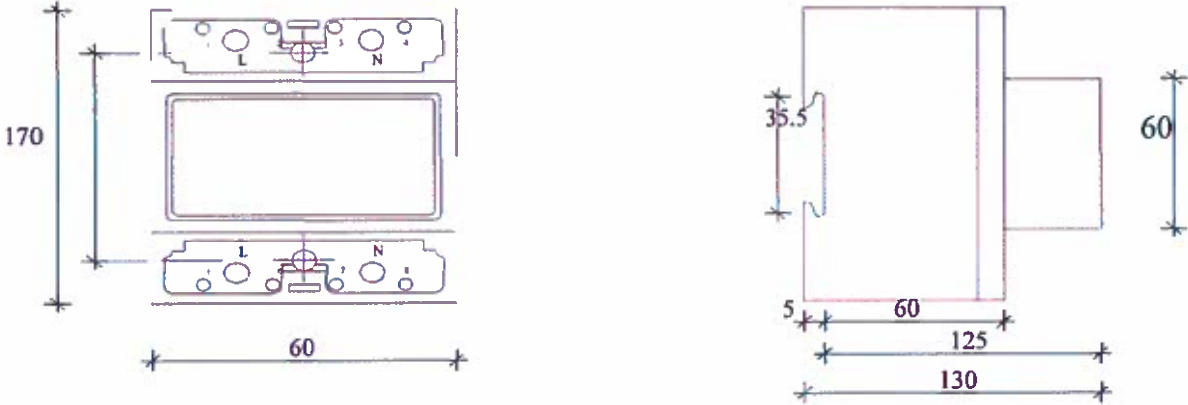

Fig. 5 Single phase meter

Appendix A. SPECIFICATION FOR POLE MOUNTED METERBOARDS

CLAUSE	KPLC REQUIREMENT	MANUFACTURER'S COMPLIANCE/REMARKS	REFERENCE PAGE IN THE SUBMITTED DOCUMENTS
2.1 a)	Altitude: 0 to 2200 metres above mean sea level		
b)	Temp: +45 C max and -1 C min, aver +30 C		
c)	Humidity: 30% to 90%, with an average of 70%.		
d)	Pollution: Design pollution level to be taken as "Heavy". Corrosion protection should take this into account.		
2.2	The meter boards are intended to be operated on 230 V single phase system with protective multiple earthing (PME).		
2.3	The meter board is to be mounted vertically on the pole. It shall be therefore suitable for mounting and operation on outdoor where raindrops shall impinge upon it.		
3.1	The degree of protection of the enclosure shall be at least IP65 when the top cover is securely closed and sealed.		
4.1	The meter board shall be rated at 100 A, 230V.		
5.1	For safety and ease of use, the meter board shall be provided with a din rail metal plate to secure the meter and miniature circuit breaker (MCB). The dimensions of the rail metal plate are as shown in fig.1		
5.2.1	It shall be preferred that the meter board shall have two (2) cable entries and two (2) cable exit glands. Fig. 3 has the details.		
5.2.2	The exit and the entry gland of the cable shall be all at the bottom of the meter board. Each cable gland shall have rubber seal sufficient to accommodate securely 16mm ² -insulated cable.		
5.3.1	The top cover shall be made of polycarbonate and easily opened by means of a hinge between it and the main meter board base; it shall be of insulation class II. Other parts shall be made of polycarbonates material, self-extinguishing and resistant to abnormal heat and fire up to 960 C, to be ascertained through glow test in accordance to IEC 60695-2-11 standard.		
5.3.2	It shall have four sealing positions to prevent tampering and access by unauthorised persons.		
5.3.3	It shall have a means of securing it firmly on the base using an Allen key. The Allen screws shall have holes (diameter 2mm) to accommodate the seal wire that will be used to seal the meter board.		
5.3.4	A galvanized/electro plated steel mounting bracket shall be provided behind the meter board to assist in securing the meter board on the pole. This mounting bracket should also have holes on the protruding parts to provide further provision to fasten the meter board tightly on the pole using 5/8" (diameter) X 11" (length) bolt."		
5.3.5	The exit and entry gland of the cables shall be fitted with rubber seal, which enhance permanent weather-proof epoxy adhesive and able to accommodate 16mm ² insulated copper wire.		
5.3.6	Din rail metal plate shall be firmly positioned as shown on fig. 1 and shall able to firmly hold the meter bearing the weight of the cables.		
5.3.7	It shall be possible to accommodate one (1) single phase meters in the meter board.		

CLAUSE	KPLC REQUIREMENT	MANUFACTURER'S COMPLIANCE/REMARKS	REFERENCE PAGE IN THE SUBMITTED DOCUMENTS										
5.3.8	The complete design of the meter board shall be as shown in fig.3												
7.1	The material shall be polycarbonates material, self-extinguishing and resistant to abnormal heat and fire up to 960 C, to be ascertained through glow test in accordance to IEC 60695-2-11 standard. For other parts, it shall be as detailed in the respective clauses. The material should be ISO 76-2 certified and certificate for conformity should be availed.												
8.1	The meter board shall have durable weather-resistant finish.												
9.1	The final colour of the meter-board shall be light aircraft grey as per pigment No. 627 of BS 381C.												
10	The meter board shall be entirely made of an insulator. Four (4) holes of three 3 mm in diameter shall also be provided for wire sealing (see fig. 3).												
11.1.1	The meter board shall measure 300 mm (Height) x 240 mm (width) x 180 mm (Height) top cover inclusive.												
11.1.2	The diameter holes for cable gland shall be 16mm ² and shall be aligned as shown in fig.3.												
11.1.3	The top cover shall be secured to the main body by means of hinge and provide a comprehensive protection of the meter from any substantial drops of water.												
11.1.4	It shall be possible to easily open the top cover to facilitate connection of the cables to the meter.												
11.1.5	The meter boards shall be capable of accommodating 1 single phase prepayment split meters.												
11.1.6	The meter boards shall come fitted with 1X4 way neutral copper terminal block as shown in figure 1.												
11.1.7	Meter din rail metal plates shall be firmly secured as shown in fig. 1 below.												
11.2.1	Polycarbonate for use outdoor as detailed in section 7.												
11.2.2	Top cover shall also be made of polycarbonate as detailed in section 7.												
11.2.3	Cable gland shall have rubber seal to enhance permanent weatherproof epoxy adhesive.												
11.2.4	Meter din rail metal plates shall either be made of galvanized steel or electro plated metal.												
11.2.5	Thickness, in millimetres, of the various components shall not be less than those indicated in the following table:												
	<table border="1"> <thead> <tr> <th></th> <th>Tolerance</th> <th>Body</th> <th>Top cover</th> <th>Rail metal plate</th> </tr> </thead> <tbody> <tr> <td>Body and top cover</td> <td>±0.1mm</td> <td>3mm</td> <td>3mm</td> <td>1± 0.05 mm</td> </tr> </tbody> </table>		Tolerance	Body	Top cover	Rail metal plate	Body and top cover	±0.1mm	3mm	3mm	1± 0.05 mm		
	Tolerance	Body	Top cover	Rail metal plate									
Body and top cover	±0.1mm	3mm	3mm	1± 0.05 mm									
11.3.1.2	Name or trade mark of the manufacturer												
11.3.1.3	Country of origin												

CLAUSE	KPLC EQUIREMENT	MANUFACTURER'S COMPLIANCE/REMARKS	REFERENCE PAGE IN THE SUBMITTED DOCUMENTS
11.3.1.4	HATARI! / DANGER! Warning of Electrical Hazard with standard symbol.		
11.3.1.5	Property of Kenya Power		
11.4	Relevant technical details, schematic drawings, operational and service manuals shall be submitted to support the tender and shall be clearly marked to indicate the type/ model of the meter board being offered.		
11.5	The Tenderer shall submit a clause-by-clause statement of compliance with these specifications in the format seen in Appendix A. In case of deviations the affected requirements shall be indicated.		
11.6	Copies of test results of the meter board being offered certified by an international or the national certification body shall be provided. If test reports / certificate(s) is (are) from accredited certification laboratories (and not national or international body), then it (they) shall be accompanied with copies of certificates of accreditation from the national or an international certification body.		
11.7	A sample of the meter board being offered shall be submitted together with the tender documents. This sample shall not be returned to the tenderer.		

Ion behalf

Declare that the above specifications matrix conforms to a typical tender meter, type..... Being offered for this tender.

Signature.....

Date.....Stamp/Seal.....

